

AL-2200

NON-STEERING AXLE AND LIFT SUSPENSION SYSTEM

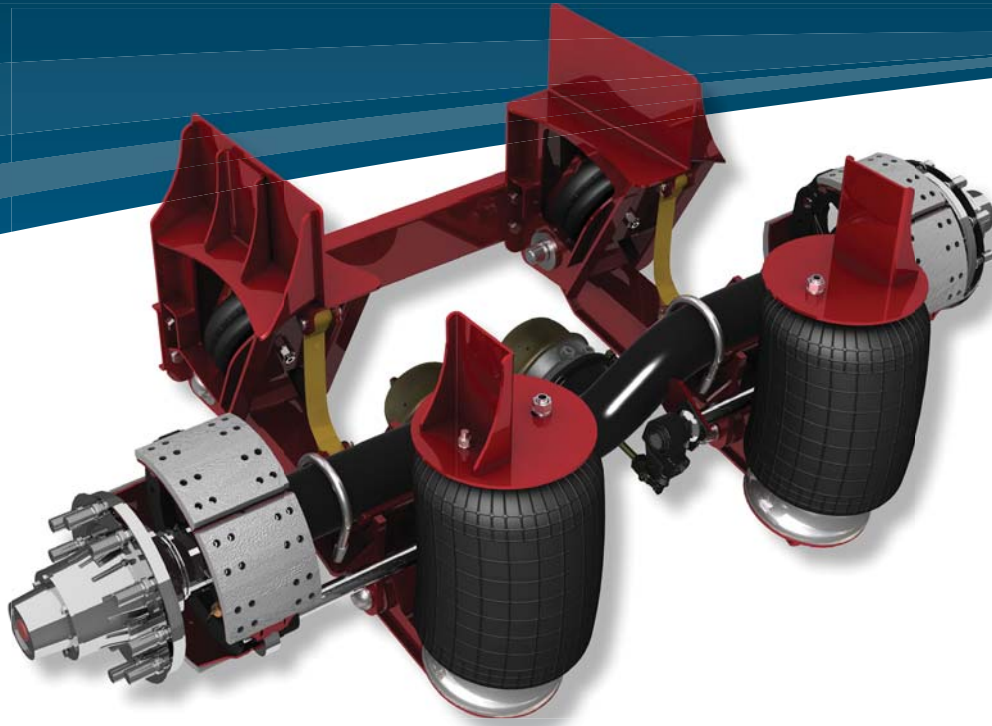

AL-2200

The AL-2200 non-steerable lift axle with a rated capacity up to 25,000 pounds has been an industry standard for many years. This model offers outstanding performance and proven durability. The AL-2200 is ideal for dump, refuse, heavy-haul and logging applications and is backed by our 5-year limited warranty*.

- 25,000 lb. suspension capacity
- Maintenance-free Huck fasteners
- Positive axle stop straps
- Ride heights: 8 thru 19 inches
- Two-pin axle connection – rubber bushed
- 5-year limited warranty*

* Contact your local Watson & Chalin representative for complete warranty terms, conditions and limitations.



Leadership in Suspension Technology

INTEGRATED SUSPENSION AND AXLE ASSEMBLY

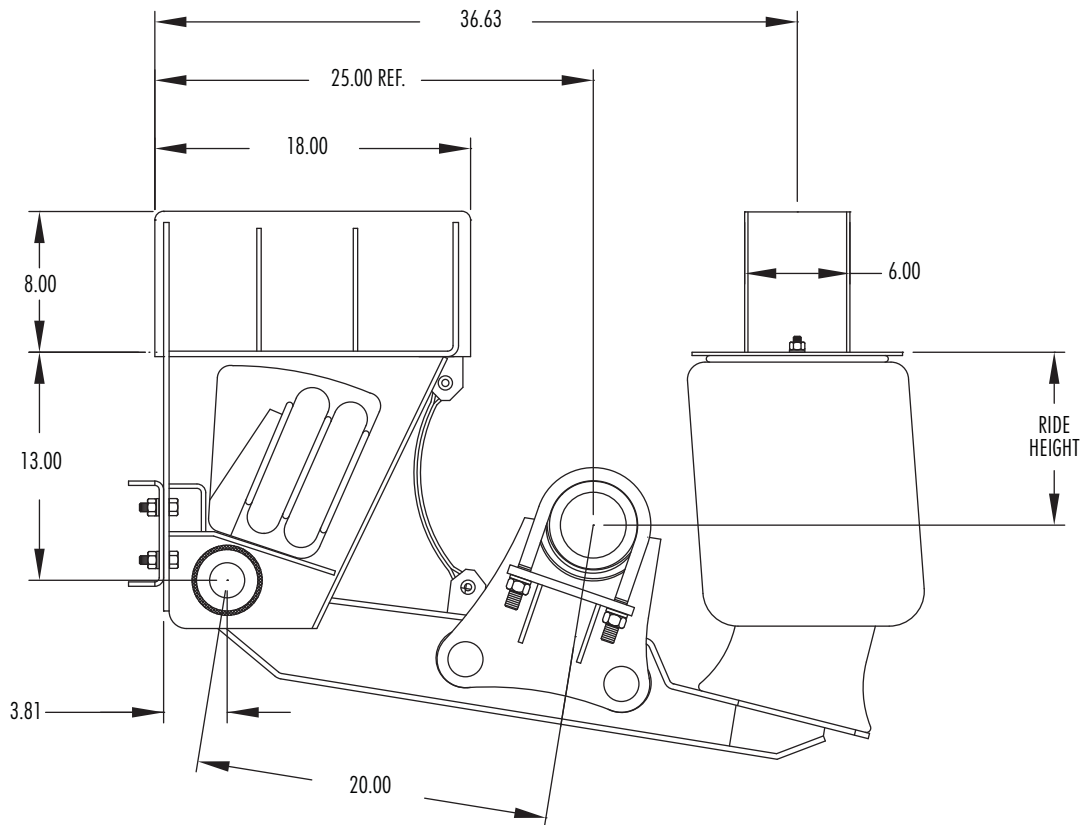

- Axle travel: 10 in.
- Capacity: 25,000 lbs.
- Lightweight: 13,200 lbs. available
- Ride heights: 8 thru 19 in.
- Maintenance-free Huck fasteners
- Available as pusher or tag assembly
- Factory pre-assembled
- Positive axle stop
- Compact design
- Air ride – air lift
- Two-pin axle connection – rubber bushed

For questions or to place
an order, please contact
HAWKEYE TRUCK EQUIPMENT
at 515-289-1755 or 1-800-622-8223.

