

DAKOTA BODIES

THE MOST VERSATILE SERVICE BODIES ON THE MARKET



For questions or to place an order, please contact
HAWKEYE TRUCK EQUIPMENT

515-289-1755 or 1-800-622-8223

SERVICE BODIES



COMPONENT BODY

2011 NTEA Work Truck Show Editors Choice Award

THE STORY

The Component Body (CB) is a modular design that allows the various components to move through the manufacturing process more efficiently. All components are powder coated at the piece part stage allowing for superior paint coverage. The painted components are assembled in the final production phase resulting in a complete service body. Our customers choose from a variety of options that can be swapped out in the field or in an up-fitters facility. Due to the modular design, parts are readily available for shipping or assembling into a specific body configuration as needed. All components of the CB body may be replaced if damaged, rather than replacing the entire body.

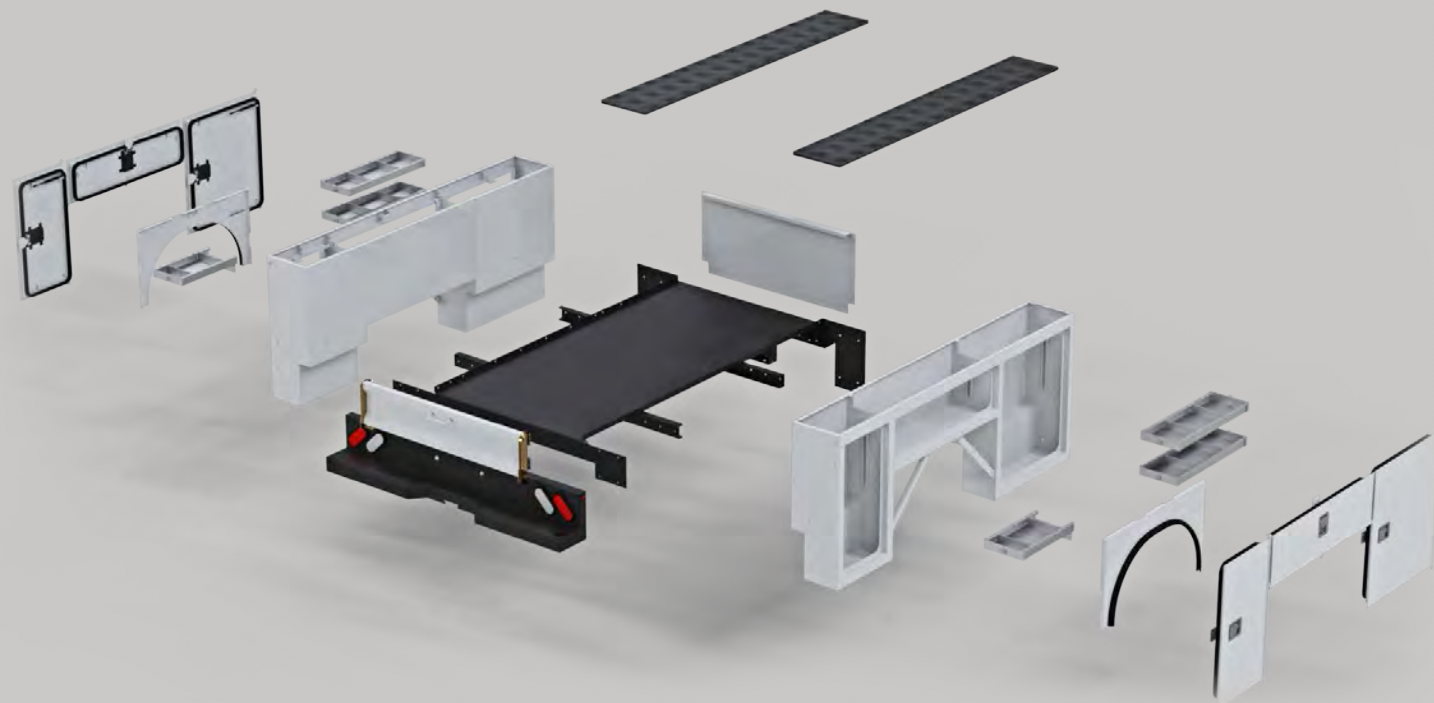

SERVICE BODY

THE STORY

The Service Body (SB) is a traditional weld together design using the same compartment configurations as the CB body. Options include a crane reinforced compartment, transverse front compartment and also a raised front compartment. Side-packs welded to the universal frame/floor eliminates the ability to easily replace the side-packs if damaged. Several bolt on options are available with this option as the overall size of the bodies are the same.



UNIVERSAL FRAME DESIGN

The Universal Frame design allows our customers to quickly turn body inventory for customers without fabricating or altering the existing frame of the body. Simply order an RTS (Ready To Ship) kit for the chassis of your choice and Dakota Bodies will provide all of the mounting parts necessary to ensure our body is properly mounted to your chassis.

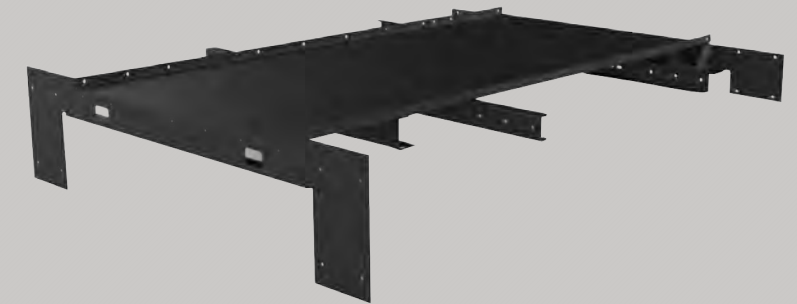

BODIES AVAILABLE IN ANY SIDE-PACK COMBINATION:

“VV” - Street-side and Curbside: “V” Configuration

“VH” - Street-side: “V” Configuration; Curbside: “H” Configuration

“HH” - Street-side and Curbside: “H” Configuration

“HV” - Street-side: “H” Configuration; Curbside: “V” Configuration

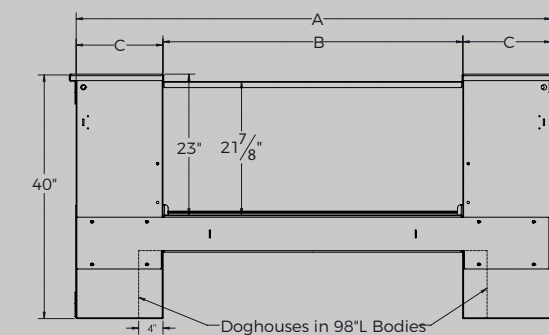
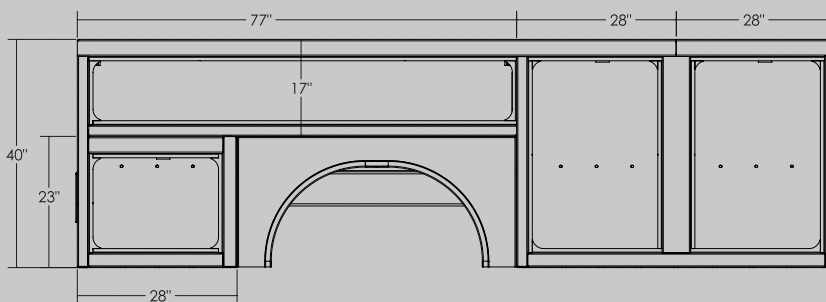
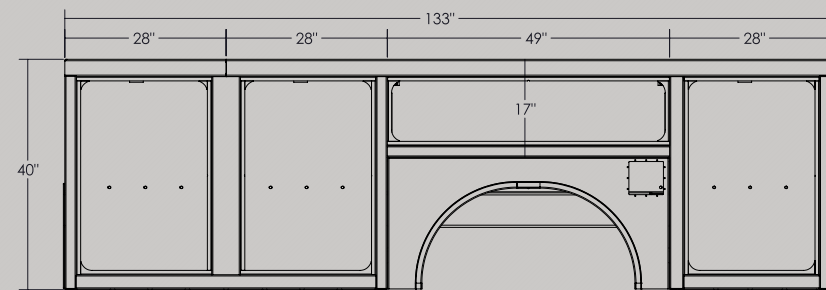
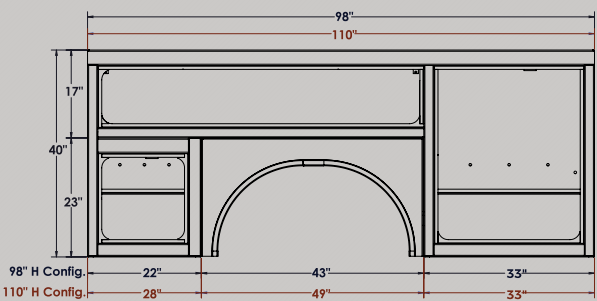
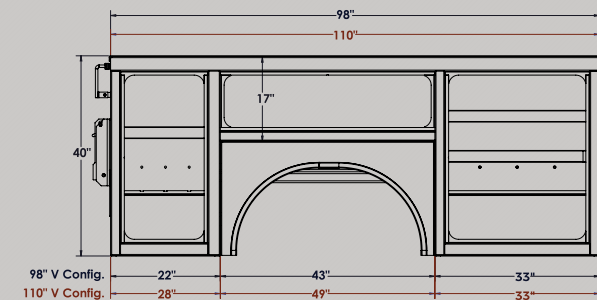

“V” Configuration (V98 & V110)

- **1st Vertical:** Two adjustable shelves with two adjustable dividers per shelf
- **Horizontal:** Open with “Pass Through” to rear vertical
- **Rear Vertical:** One adjustable shelf with two adjustable dividers

“H” Configuration (H98 & H110)

- **1st Vertical:** Two adjustable shelves with two adjustable dividers per shelf
- **Horizontal:** One removable shelf with four adjustable dividers
- **Rear Vertical:** Open

“V” Configuration (V133)

- **1st Vertical:** Two adjustable shelves with two adjustable dividers per shelf
- **2nd Vertical:** Two adjustable shelves with two adjustable dividers per shelf
- **Horizontal:** Open with “Pass Through” to rear vertical
- **Rear Vertical:** One adjustable shelf with two adjustable dividers

“H” Configuration (H133)

- **1st Vertical:** Two adjustable shelves with two adjustable dividers per shelf
- **2nd Vertical:** Two adjustable shelves with two adjustable dividers per shelf
- **Horizontal:** One removable shelf with four adjustable dividers
- **Rear Vertical:** Open

BODY SIZE	CA	A	B	C
Pick-up Box Delete				
98" SRW	56"	78"	49-1/4"	14-1/4"
98" DRW	56"	94"	49-1/4"	22-1/4"
Chassis Cab				
110" SRW	60"	78"	49-1/4"	14-1/4"
110" DRW	60"	94"	49-1/4"	22-1/4"
133" DRW	84"	94"	49-1/4"	22-1/4"

SERVICE BODIES	CB	SB
MATERIALS		
ALUMINUM	✓	✓
STAINLESS	✓	✓
A60 GALVANNEAL	✓	✓
CONSTRUCTION		
Assembly	Mechanical Fasteners	Welded
Removable Fender Panel	✓	✓
Universal Frame	✓	✓
LED Rope Lighting	✓	✓
Floor	Smooth with Black Lava Powder Coat	Painted Treadplate Optional: Grip-deck
Compartment Tops	Bolt-On Aluminum Treadbrite Optional: Bolt-On Treadbrite Flip Top	Smooth, Painted Galvanneal (std steel) Optional: Painted Treadplate Bolt-On Treadbrite (std aluminum) Bolt-On Treadbrite Flip Top Grip-deck
Crane Reinforced Compartment	N/A	Available in 110" & 133" Bodies
Transverse 1st Vertical	N/A	✓
Raised 1st Vertical	N/A	✓

STANDARD FEATURES

- BODY - POWDER COATED WHITE FINISH
- UNDERSTRUCTURE AND BUMPER COATED WITH NON-SLIP BLACK LAVA POWDER COAT
- GAS CYLINDER STYLE DOOR HOLDERS
- LED REAR LIGHTING WITH WIRING HARNESS
- "CRASH ZONE" REAR BUMPER WITH RECESS
- STUD MOUNTED STAINLESS STEEL LATCHES
- VISE SOCKET IN BUMPER
- UNIVERSAL FRAME AND BUMPER MOUNTING KIT
- AUTOMOTIVE BULB TYPE WEATHERSTRIP
- DOUBLE PANEL DOORS WITH INTERNAL REINFORCEMENTS

COMPARTMENT TOPS

- STATIONARY (STD)
- FLIP TOPS WITH TRAY

CRASH ZONE BUMPER

- RECESSED (STD)
- FULL STEP
- PUNCHED

WISE SOCKET

- STANDARD FEATURE

MATERIAL RACK/LADDER RACK

- LIGHT DUTY LADDER RACK
- HEAVY DUTY LADDER RACK
- ANGLED LADDER RACK
- HEAVY DUTY OVERHEAD MATERIAL RACK

COMPARTMENT OPTIONS

- ADJUSTABLE SHELVES
- ADJUSTABLE DRAWERS
- ADJUSTABLE HOOKS
- SMALL PARTS FRICTION DRAWER SET
- STAINLESS STEEL ROTARY LATCH (STD)
- CUSTOM LOGO LATCH
- COMPRESSION T-HANDLE

PASS THROUGH PANEL

REMOVE PERFORATED PANEL TO CONVERT A "V" SIDE PACK INTO AN "H" SIDE PACK. STANDARD ON ALL "V" SERVICE BODY SIDE PACKS.



ACCESSORIES



Slide Drawers

- Available in 1, 2 and 3 drawer sections
with 250# or 500# capacity slides



Small Parts Friction Drawer Set



Adjustable Hook Rail

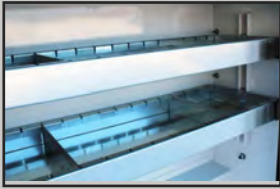

Adjustable Divider Shelves



Tie Down Ring



Master Lock System



Headache Rack



Heavy Duty Over Head Material Rack

- Adjustable to fit 98" & 110" service bodies



Angled Ladder Rack

- Available for Curbside and Street-side



Light Duty Ladder Rack

- Able to fit 98", 110" and 133" service bodies



Heavy Duty Ladder Rack

- Adjustable to fit 98" & 110" service bodies



Side Mounted Tie Down



Powder Coated Bumper

- Recessed Bumper (STD)
- Full Step Bumper
- Punched Tread Bumper



E-Track Bed Tie Down System



For questions or to place an order, please contact
HAWKEYE TRUCK EQUIPMENT
515-289-1755 or 1-800-622-8223