

EC3200

THE EC SERIES OF SERVICE CRANES BY





■ SPECIFICATION INFORMATION

Crane Rating:	11,500 ft-lbs (1.59 ton-meters)
Standard Boom Length:	7' (2.13 m) from CL of Crane
Boom Extension:	
• 1st stage:	Hydraulic 48" (121.9 cm)
• 2nd stage:	Manual 48" (121.9 cm)
Max. Horizontal Reach:	15' (4.57 m) from CL of Crane
Maximum Vertical Lift: (from crane base)	16' 2" (5.28 m)
Boom Elevation:	-5 to +80 degree
Stowed Height: (crane only)	24" (61.0 cm)
Mounting Space Required:	18" x 15" (45.7 x 38.1 cm)
Shipping Weight:	730 lbs (331 kg)
Controls:	Radio control standard for all functions
Winch	
• Rope Length:	65' (19.8 m)
• Rope Diameter:	7/32" (.56 cm)
• Line pull speed:	15 ft/min (4.6 m/min)
• Max. single part line:	1600 lbs (725 Kg)
• Max. double part line:	3200 lbs (1450 Kg)
Rotation:	410 degree power (worm gear)
Lifting Capacities:	1625 lbs @ 7' (737 Kg @ 2.1 m) 640 lbs @ 15' (260 Kg @ 4.6 m)
Power Supply Required:	12 volt power unit 2.0 gpm @ 2600 psi (7.57 lpm @ 179 bars)

■ DEFINING CHARACTERISTICS

Planetary Drive Winch System

The winch is equipped with a 1.8 HP permanent magnet electric motor with a 261:1 planetary gear reduction system. This ensures that your winch will never quit lifting before it reaches the full rated capacity.

Double Boom Design

The double boom design makes it nearly twice as strong as the nearest competitor.

Gear Bearing Rotation

Uses same rotation system as the larger class cranes. There are no plastic bushings or brass gears in the rotation system. It uses a high strength steel ball bearing turntable gear, a high strength steel worm gear, and a cast steel worm gear housing.

Integral Rotation Stop

410 degrees of rotation with an integrated rotation stop. Integrated stops allow you the greatest performance while protecting wires and hoses from damage.

15' of Reach

Hydraulic 1st stage extension. Manual 2nd stage extension.

Radio Remote

Comes standard with a radio remote control.

■ EC3200 CAPACITY CHART

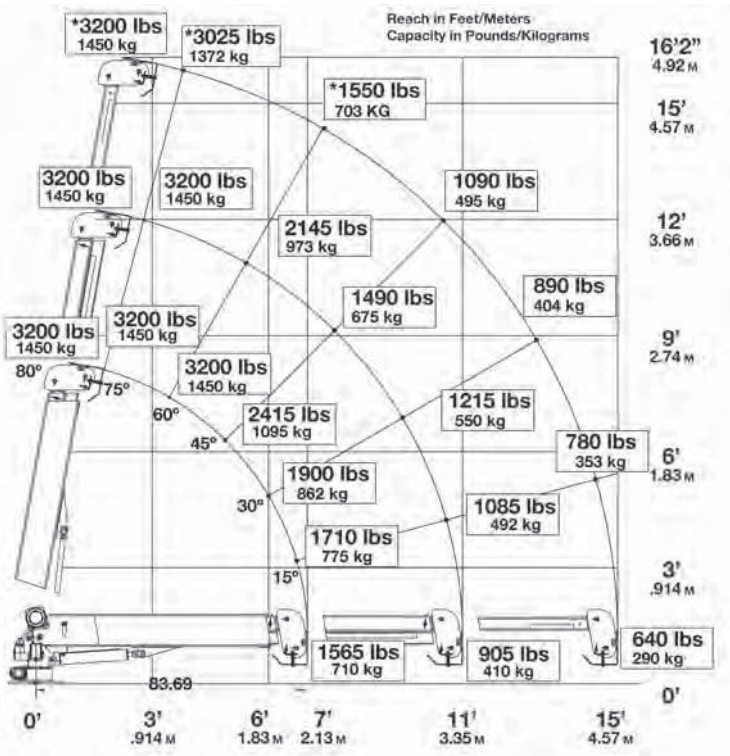

Weight of load handling devices are part of the load lifted and must be deducted from the capacity.

Maximum 1 - part line capacity is 1600 lbs. (726 kg). For greater loads, use 2 - part line.

■ GEOMETRIC DIMENSIONS

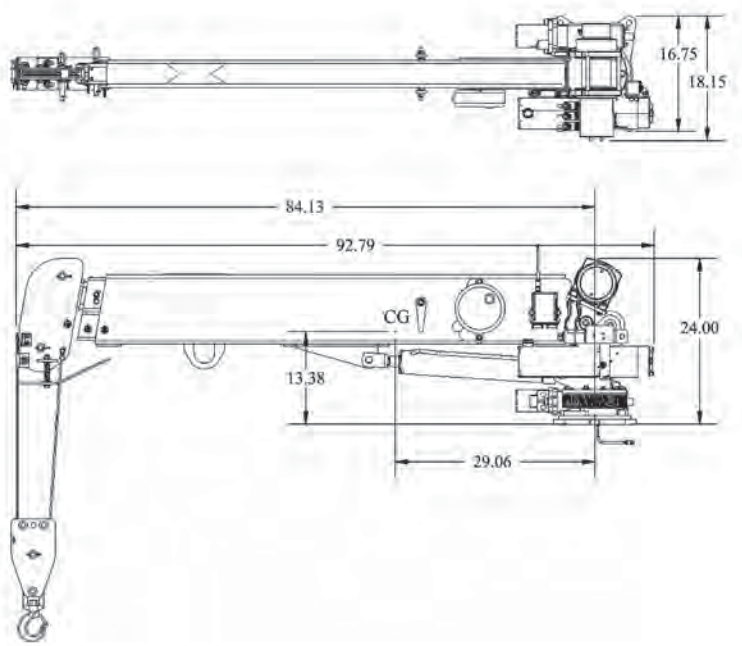

■ ROTATIONAL CLEARANCE

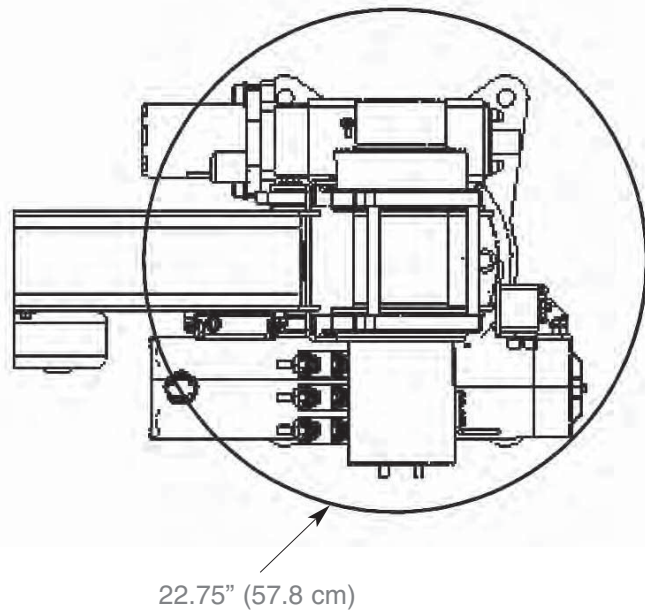

■ HOLE MOUNTING DETAIL

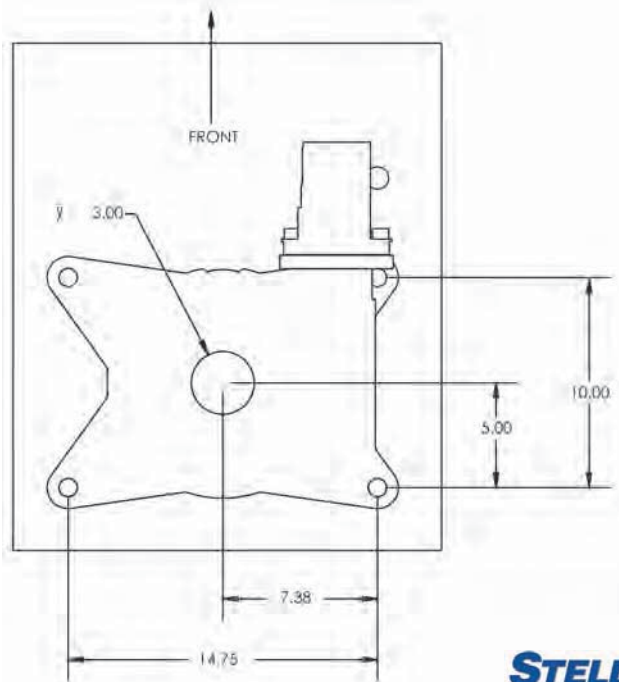

■ **Narrow Service Body Mount**

Mounts on 14" deep (or larger) side packs.

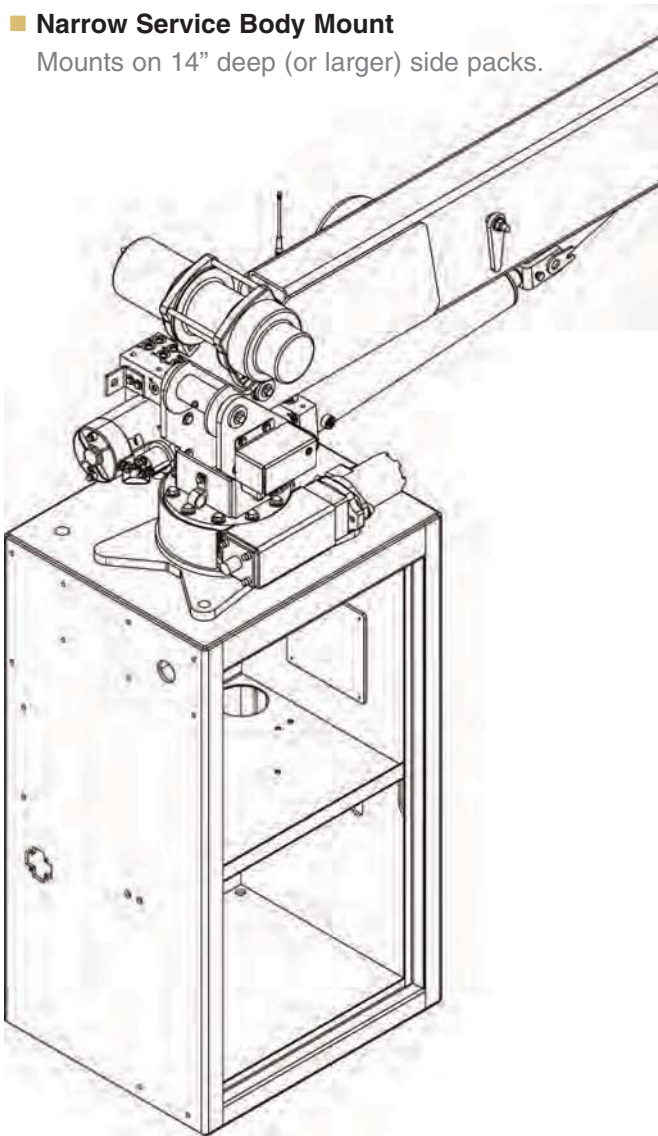

■ **Wide Service Body Mount**

Mounts on 20" deep (or larger) side packs.

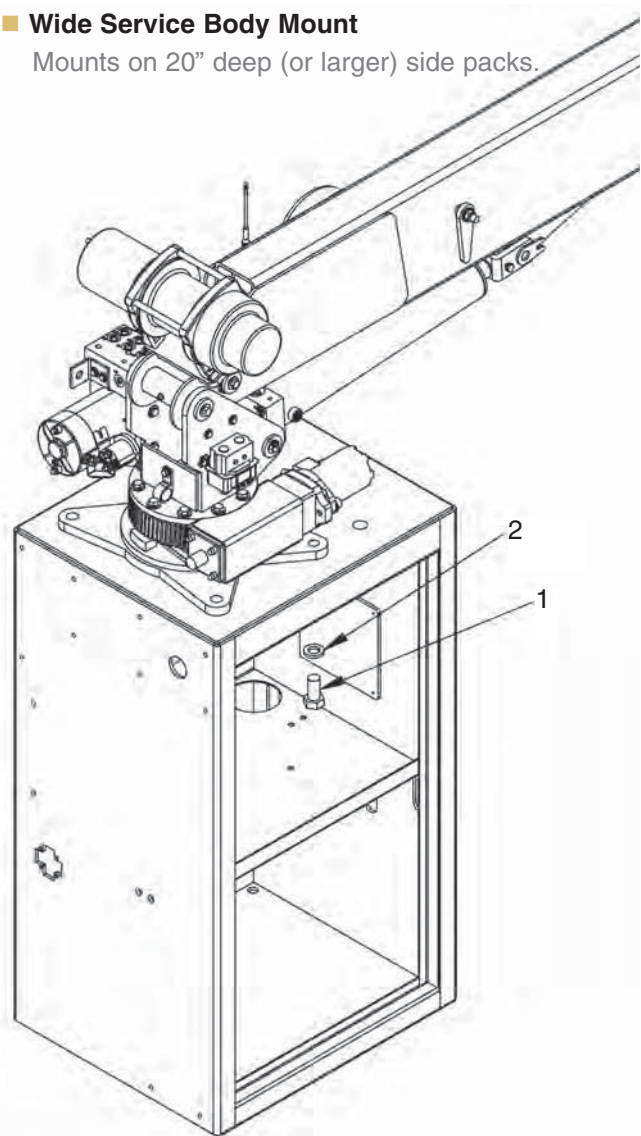

Item	Part	Description	Qty.
1	42985	Cap Scr 0.88-9x1.75 HHGR8ZY	4
2	8648	Washer 0.88 SAE GR8	4



For questions or to place an order, please contact **HAWKEYE TRUCK EQUIPMENT** at 515-289-1755 or 1-800-622-8223.