

Hi-Way **XZALT**TM

Precision Applicator



For questions or to place an order, contact
HAWKEYE TRUCK EQUIPMENT
515-289-1755 or 1-800-622-8223

70:30 Application

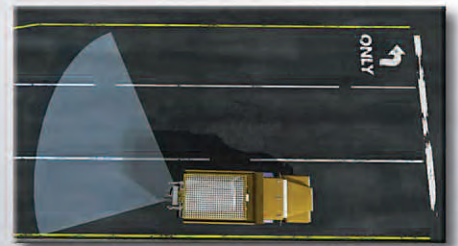
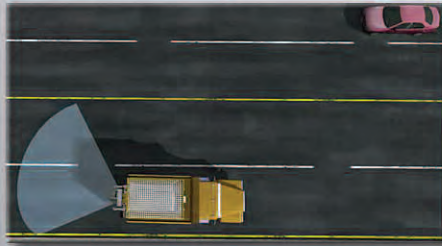
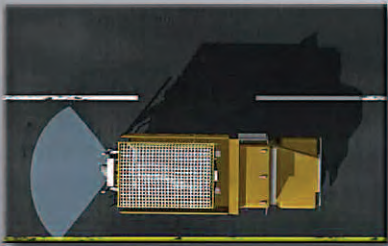

Return on Investment



Directional Spinner System



Spreader Control



More Features & Benefits



More Features & Benefits



Xzalt™ Specifications

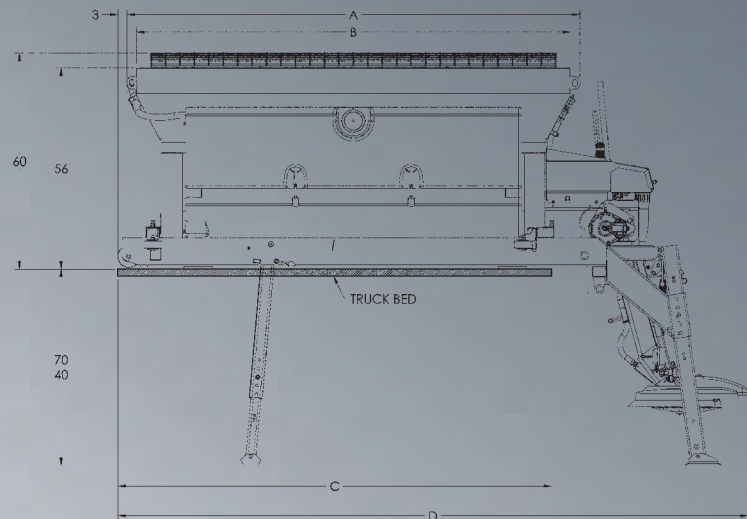
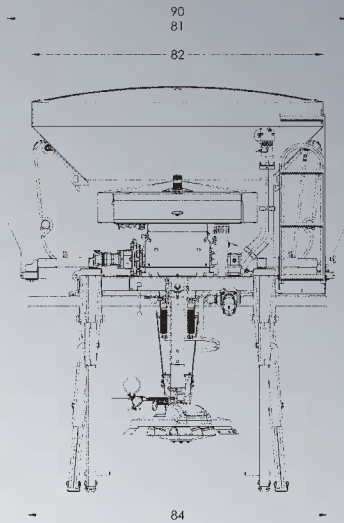

feet (m)	inches (cm)	inches (cm)	inches (cm)	inches (cm)	cubic yards (cu.m)	cubic yards (cu.m)	gallons (liters)	Spreader Weight pounds (kg)
								3375 (1531)
								3915 (1776)
								4455 (2021)

For questions or to place an order, contact
HAWKEYE TRUCK EQUIPMENT
 515-289-1755 or 1-800-622-8223



Hi-Way partners with approximately 75 stocking dealers throughout North America. To locate your dealer, go to www.highwayequipment.com.

Products and specifications subject to change without notice. Photos and illustrations may or may not include optional equipment. Hi-Way® is a registered trademark of Highway Equipment Company. FORCE® is a registered trademark of FORCE America, Inc. Copyright 2011 Highway Equipment Company, Inc. Form No. HI131-2011-12