

# SL-1190 TRU-TRACK ALUMILITE

## SELF-STEERING AXLE AND LIFT SUSPENSION SYSTEM



## SL-1190

The SL-1190 TRU-TRACK Alumilite with a rated capacity up to 13,500 pounds is our most popular capacity steerable model and incorporates our "quick-change ride height system". The SL-1190 is ideal for dump, mixer, refuse and heavy-haul applications. It is lightweight yet durable utilizing Huck fasteners at the pivot points. Our Super Short Rail version (SSR) offers a more compact mounting design when space requirements become critical. All TRU-TRACK lift axles are backed by our 5-year limited warranty\*.

- 13,500 lb. suspension capacity
- Compact packaging design of 22.1 inches - SSR
- Ride heights 7 thru 16 in.
- Maintenance-free Huck fasteners
- Quick-change ride height system
- 5-year limited warranty\*

\* Contact your local Watson & Chalin representative for complete warranty terms, conditions and limitations.



*Leadership in Suspension Technology*

**INTEGRATED SUSPENSION AND AXLE ASSEMBLY**

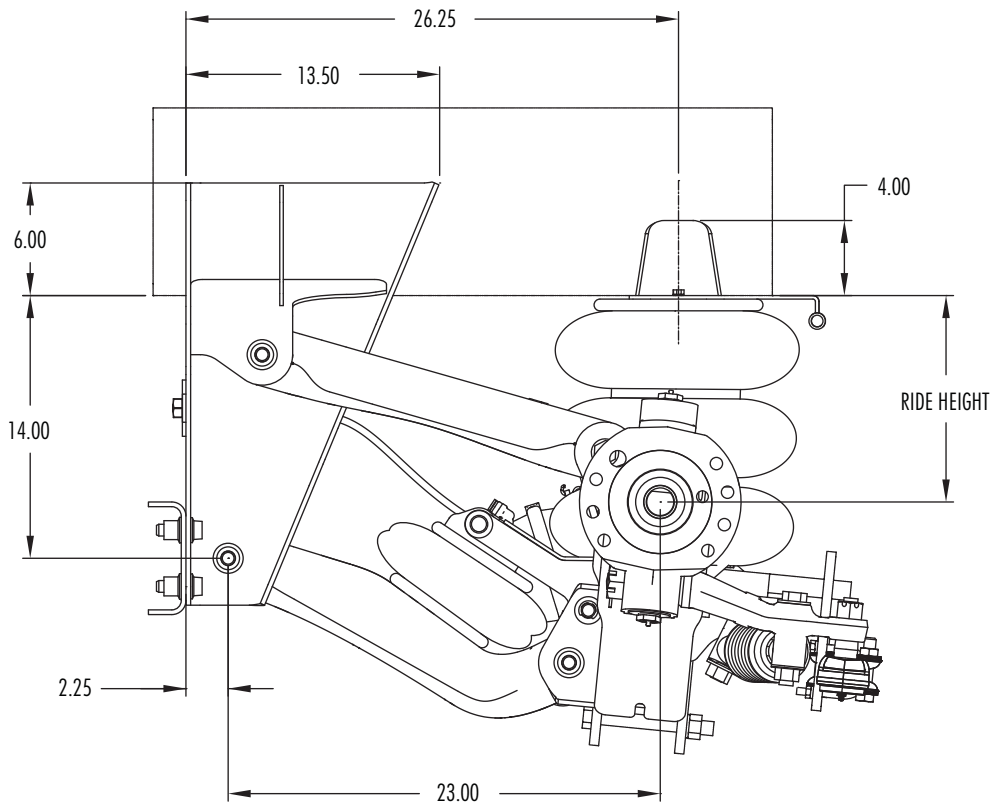

- Axle travel: Up to 13.5 in.
- Capacity: 13,500 lbs.
- Axle lift: Up to 11 in.
- Ride heights: 6 thru 16 in.
- Quick-change ride height system
- Factory pre-plumbing available
- Preset caster
- Air ride – air lift
- Parallelogram design
- Extended life bushings

For questions or to place an order, please contact **HAWKEYE TRUCK EQUIPMENT** at 515-289-1755 or 1-800-622-8223.

