

# SL-2065 20K TRU-TRACK

## SELF-STEERING AXLE AND LIFT SUSPENSION SYSTEM

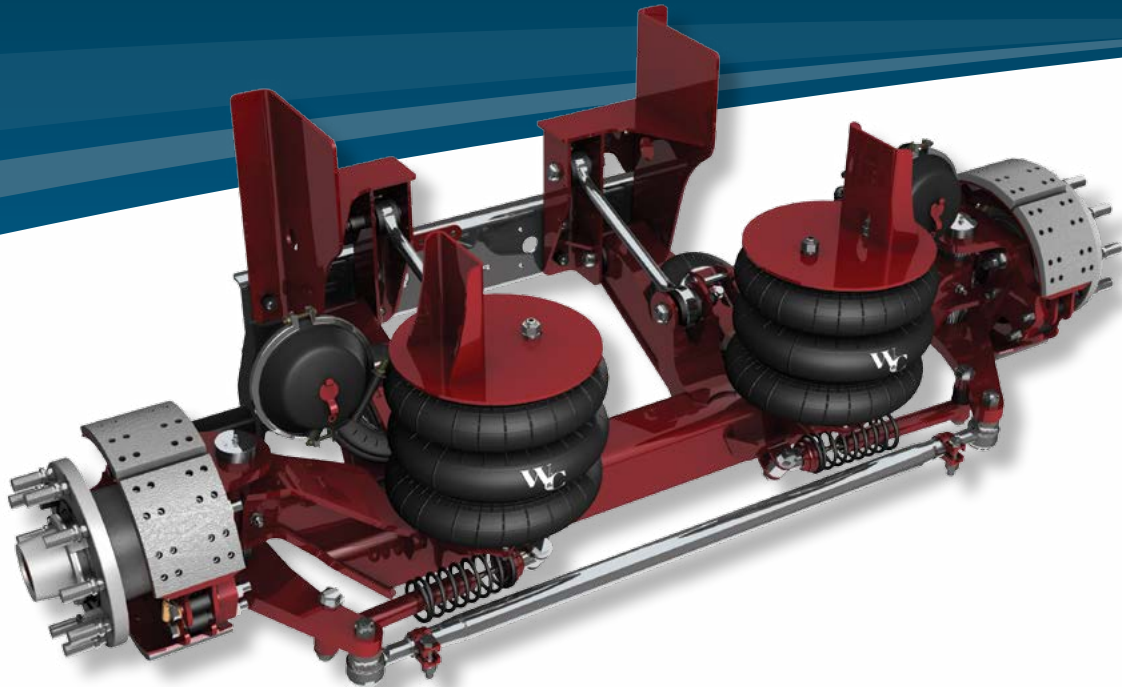

## SL-2065

The 20K Tru-Track SL-2065 with a rated capacity of 20,000 pounds sets the standard as a robust and innovated steerable lift axle. Weighing in at 1,327 pounds, the SL-2065 maintains the durability and features that you have come to expect from Watson & Chalin by delivering exceptional maneuverability with an industry leading 25 degrees of wheel cut while accepting 445/65R22.5 tires. The vertically integrated SL-2065 is currently available in truck mounts and trailer mounts while offering Huck fasteners at the pivot points and backed by our 5-year limited warranty\*.

- 20,000 pound suspension capacity
- Maintenance-free Huck fasteners
- Compatible with 445/65R22.5 tires
- Quick-change ride height system
- 5-year limited warranty\*

\* Contact your local Watson & Chalin representative for complete warranty terms, conditions and limitations.



Leadership in Suspension Technology

## INTEGRATED SUSPENSION AND AXLE ASSEMBLY

A unique parallelogram design provides a 26.5 inch packaging space allowing easier configurations and is offered in ride heights from 8 to 13 inches and features a quick-change ride height system.

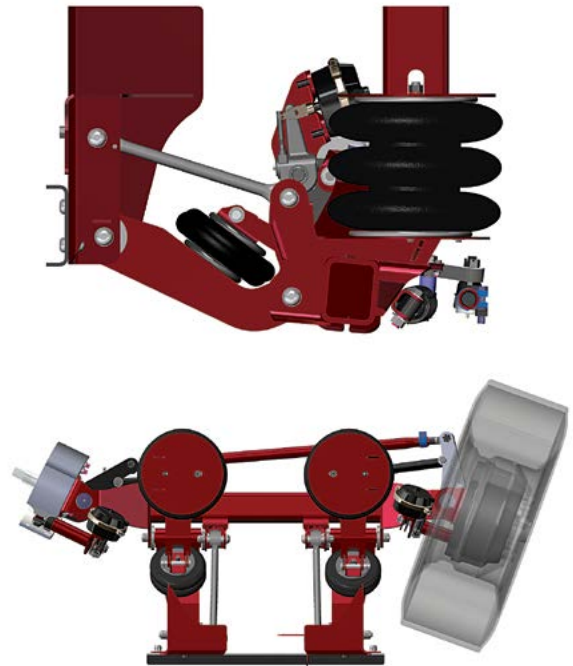
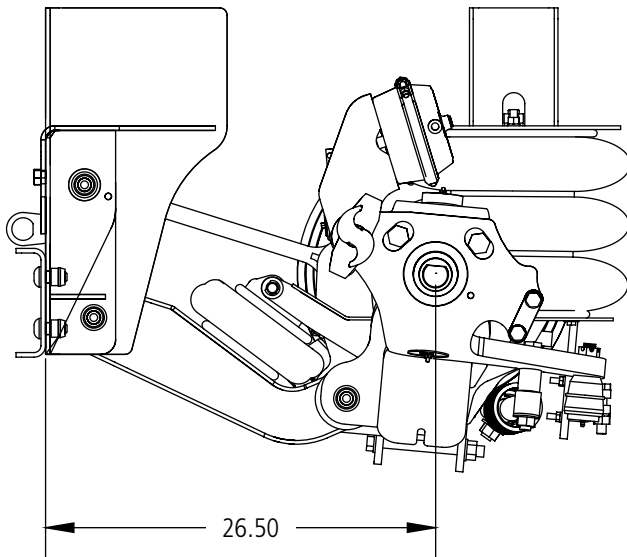

- Axle travel: 12 in.
- Capacity: 20,000 lbs.
- Axle lift: Up to 8 in.
- Ride heights: 8 thru 13 in.
- 25 degree wheel cut
- Preset caster
- Pre-plumbed options
- Narrow 89 drumface for increased body clearance
- Lightweight: 1,327 pounds
- Reverse lock-out kit available
- Dual self-centering stabilizers
- Air-ride – air lift
- Parallelogram design
- Fabricated axle
- Huck and threaded fasteners available
- Adjustable ride heights with interchangeable lower plates

For questions or to place an order, please contact **HAWKEYE TRUCK EQUIPMENT** at 515-289-1755 or 1-800-622-8223.

