



STELLAR® 3315 TECHNICAL SPECIFICATION GUIDE

3315

Service Crane and T1-11 Service Body



Our People. Our Products.

STELLAR® 3315 TECHNICAL SPECIFICATION GUIDE

■ SPECIFICATION INFORMATION

Crane Rating: 11,500 ft-lbs (1.59 ton-meters)
Standard Boom Length: 7' (2.13 m) from CL of Crane

Boom Extension:
• 1st stage: Hydraulic 48" (121.9 cm)
• 2nd stage: Manual 48" (121.9 cm)

Max. Horizontal Reach: 15' (4.57 m) from CL of Crane

Maximum Vertical Lift: 16' 9" (5.11m)
(from crane base)

Boom Elevation: -5 to +80 degree

Stowed Height: 32.5" (82.6 cm)
(crane only)

Mounting Space Required: 18" x 15" (45.7 x 38.1 cm)

Shipping Weight: 800 lbs (360 kg)

Controls: Radio control standard for all functions

Winch

- Rope Diameter: 1/4" (.64 cm)
- Line pull speed: 30 ft/min (9.1 m/min)
- Max. single part line: 1600 lbs (725 Kg)
- Max. double part line: 3200 lbs (1450 Kg)

Rotation: 370 degree power
(worm gear)

Lifting Capacities: 1625 lbs @ 7' (737 Kg @ 2.1 m)
750 lbs @ 15' (340 Kg @ 4.6 m)

Power Supply Required: 12 volt power unit
2.0 gpm @ 2300 psi
(7.57 lpm @ 159 bars)

(Also available in hydraulic versions)

■ DEFINING CHARACTERISTICS

Planetary Drive Winch System

To maximize winch speed, Stellar Industries has incorporated a planetary drive winch system with line speeds up to 30-feet per minute. In addition to speed, the planetary winch also provides mechanical and hydraulic breaks for added security.

Hexagonal Boom Design

Hexagonal booms are stronger and greatly reduce boom flex and side to side movement.

Greaseless Bushings

Maintenance free greaseless bushings.

Stainless Steel Pivot Pins

Lower maintenance and extend life.

15' of Reach

Hydraulic 1st stage extension. Manual 2nd stage extension.

Dual Acting Counter Balance Valves

Integrated into cylinders.

Flip Sheave Standard

Anti Two-Block Device

3315 CAPACITY CHART

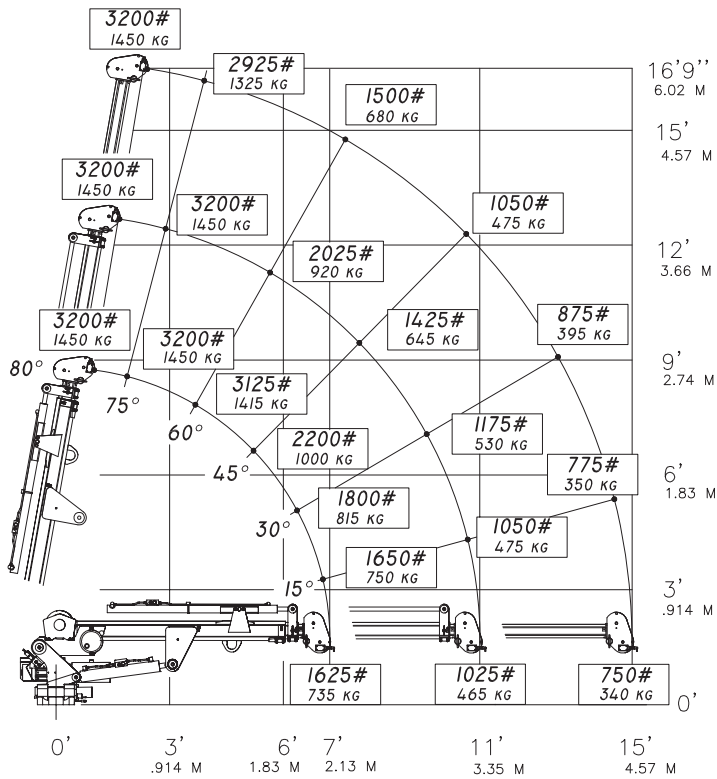

Weight of load handling devices are part of the load lifted and must be deducted from the capacity.

Maximum 1 - part line capacity is 1600 lbs. (725 kg). For greater loads, use 2 - part line.

GEOMETRIC DIMENSIONS

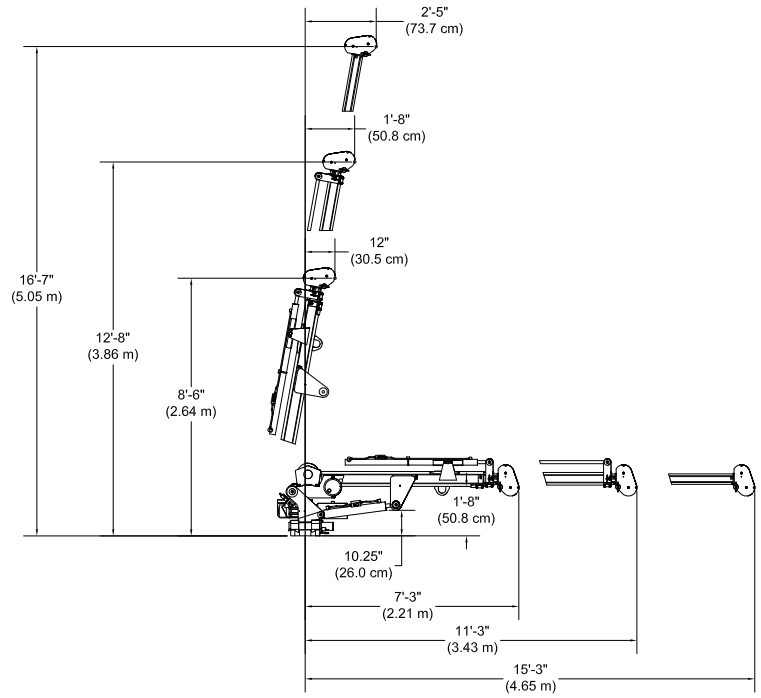

ROTATIONAL CLEARANCE

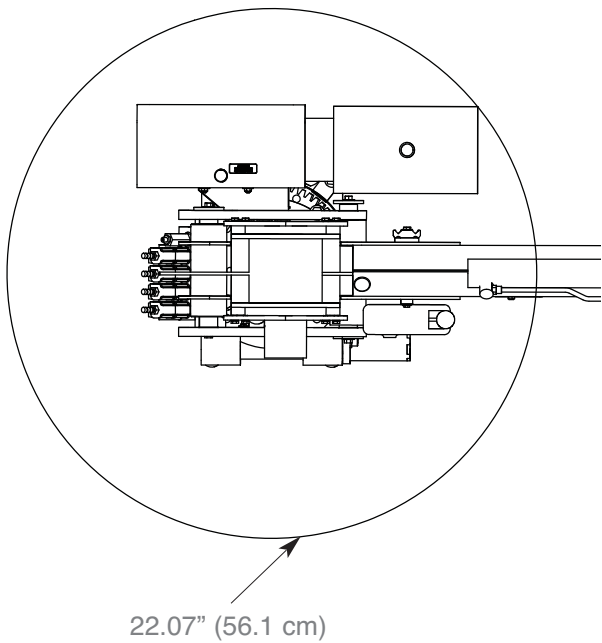

HOLE MOUNTING DETAIL

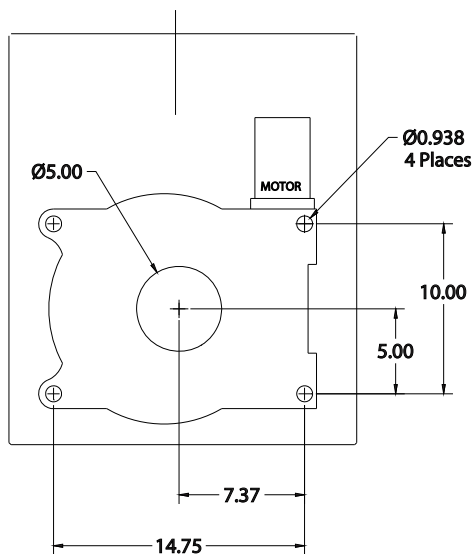

■ Service Bodies

T1-11 Service Body

Applicable Chassis: 16000 GVWR to
19000 GVWR Chassis

Crane Models: 3315
4420
5520
6620
6628

Cab to Axle: 84" (213.36 cm)
Body Length Nominal: 133" (337.82 cm)
Body Height: 44" (111.76 cm)
Body Width: 94" (238.76 cm)
Compartment Depth: 22" (55.88 cm)
Floor Width: 50" (127 cm)
Net Weight: 3220 lbs (1460.37 kg)

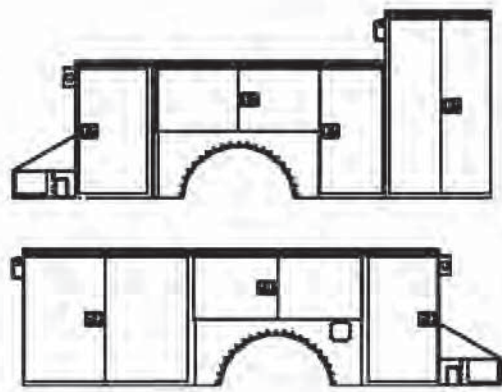
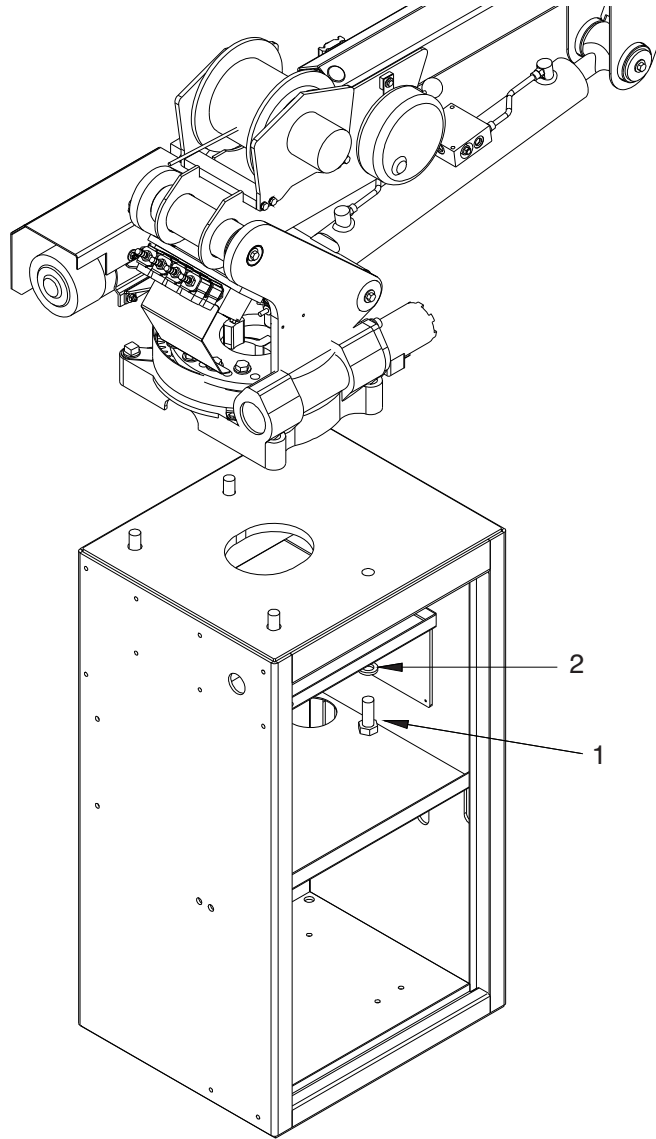

Item	Part	Description	Qty.
1	17688	Cap Scr 0.88-9x2.25 HHGR8	4
2	8648	Washer 0.88 SAE GR8	4



For questions or to place an order, please contact HAWKEYE TRUCK EQUIPMENT at 515-289-1755 or 1-800-622-8223.