



STELLAR[®]
CDT[™]
EQUIPPED

STELLAR[®] 5521 TECHNICAL SPECIFICATION GUIDE

5521

Service Crane and TMAX[™] Service Body



Our People. Our Products.

STELLAR® 552I TECHNICAL SPECIFICATION GUIDE

■ SPECIFICATION INFORMATION

Crane Rating:	29,500 ft-lb (4.1 ton-m)*
Standard Boom Length:	11' 0" (3.35 m) from CL of Crane
Boom Extension:	
• 1st stage:	Hydraulic 60" (152.4 cm)
• 2nd stage:	Hydraulic 60" (152.4 cm) Manual 60" (optional)
Max. Horizontal Reach:	21' 0" (6.40 m) from CL of Crane
Max. Vertical Lift: (from crane base)	22' 10" (6.95 m)
Boom Elevation:	-5° to +80°
Stowed Height: (crane only)	32" (81.3 cm)
Mounting Space Required:	20" x 21" (50.8 x 53.3 cm)
Shipping Weight:	1400 lbs (635 kg)
Controls:	Radio control standard for all functions
Winch	
• Rope Diameter:	5/16" (.794 cm)
• Line Pull Speed:	70 ft/min (21.34 m/min)
• Max. Single Part Line:	2500 lbs (1135 kg)
• Max. Double Part Line:	5000 lbs (2265 kg)
Rotation:	400° power (worm gear)
Lifting Capacities:	5000 lbs @ 5'10" (2265 kg @ 1.78 m)** 1400 lbs @ 21' (635 kg @ 6.40 m)**
Power Supply Required:	PTO & Pump 8.0 gpm @ 2500 psi (30.31 lpm @ 173 bar)

■ DEFINING CHARACTERISTICS

Stellar® CDT™ Equipped

The Stellar CDT equipped cranes will engage and communicate with the crane operator by using multiple sensory indicators when approaching maximum capacity. This will include the use of colored LED lights and pulsating vibrations on the handheld remote. The Stellar CDT control system will also allow the operator to go into a boost mode and operate at 118% of its normal operating capacity for a short period of time.

Remote Control

Stellar Industries was the first U.S. manufacturer to include the state-of-the-art fully proportional multi-functional remote control as a standard feature. The radio remote incorporates a variable speed trigger that allows the operators to feather the crane with precise control. Additionally, the radio remote control handle features engine start/stop functions, compressor on/off, engine speed controls, and an emergency shut-off. It also has LED lights and the ability to vibrate to indicate capacities.

Planetary Drive Winch System

To maximize winch speed, Stellar Industries has incorporated a planetary drive winch system with line speeds up to 70 ft/min (21.34 m/min), giving the 5521 crane over twice the speed of competitors with worm drive winches. In addition to speed, the planetary winch also provides mechanical and hydraulic breaks for added security.

Hexagonal Boom Design

Hexagonal booms are stronger and greatly reduce boom flex and side to side movement.

Greaseless Bushings

Maintenance free greaseless bushings.

Stainless Steel Pivot Pins

Lower maintenance and extend life.

21' of Hydraulic Reach

2-stage hydraulic extensions or hydraulic/manual extensions

Dual Acting Counter Balance Valves

Integrated into cylinders.

Flip Sheave Standard

Anti Two-Block Device

NOTE: All Stellar cranes meet ANSI B30.5 and OSHA 1910.180 specifications. Specifications subject to change without notification.

*Crane rating in Boost Mode. Normal crane rating is 25,000 ft-lbs (3.46 ton-m)

**Maximum capacities in Boost Mode.

5521 CAPACITY CHART

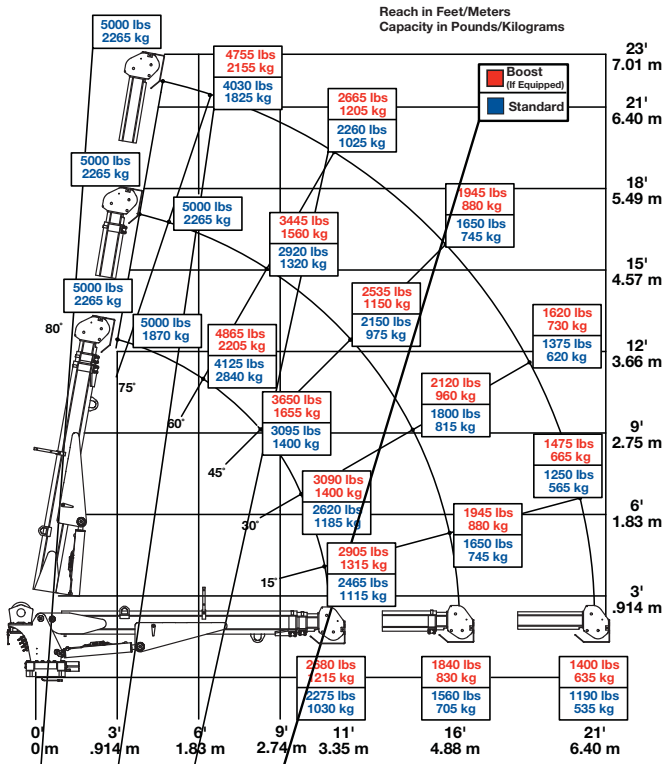

Weight of load handling devices are part of the load lifted and must be deducted from the capacity.

Maximum 1-part line capacity is 2500 lbs. (1130 kg). For greater loads, use 2-part line.

GEOMETRIC DIMENSIONS

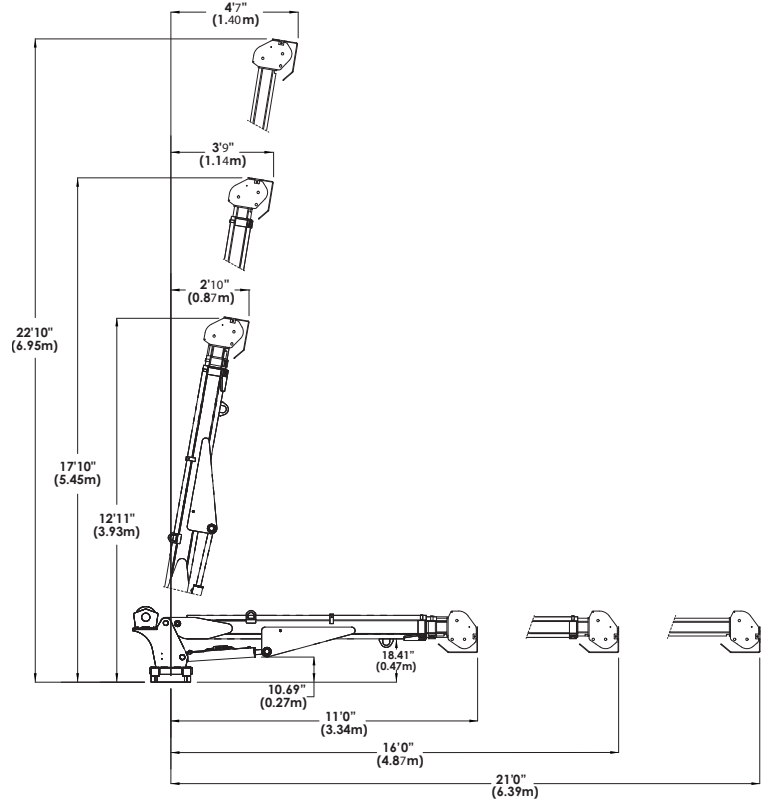

ROTATIONAL CLEARANCE

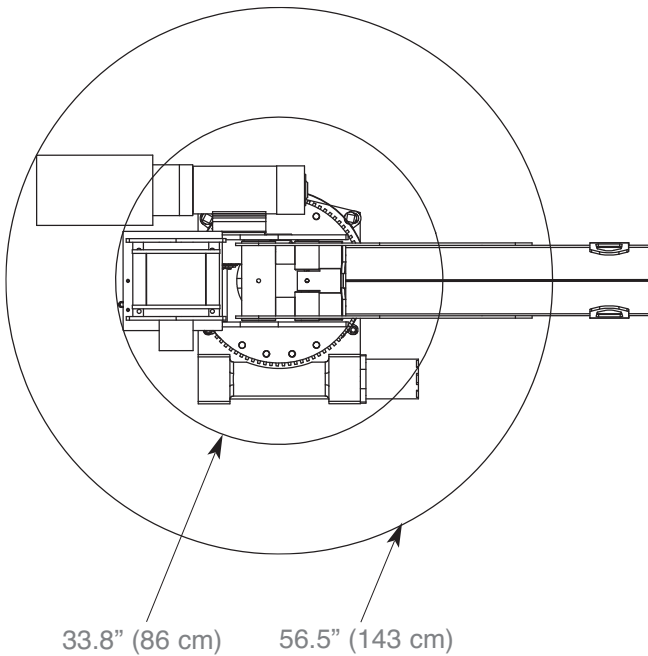

HOLE MOUNTING DETAIL

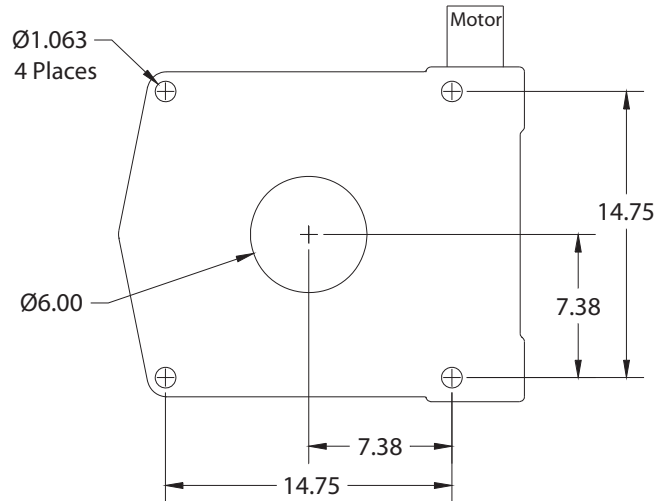

■ **TMAX™ Service Bodies**

TMAX1™ Service Body

Applicable Chassis: 16000 GVWR to
19000 GVWR Chassis

Crane Models: 3315
4420
5521
7621
7628

Cab to Axle: 84" (213.36 cm)
Body Length Nominal: 133" (337.82 cm)
Body Height: 44" (111.76 cm)
Body Width: 94" (238.76 cm)
Compartment Depth: 22" (55.88 cm)
Floor Width: 50" (127 cm)
Net Weight: 3220 lbs (1460.37 kg)

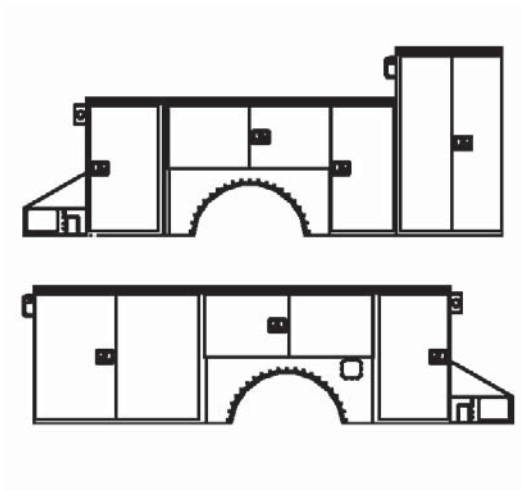

■ **Stellar® Crane Dynamics Technology™ (CDT™)**

A proprietary collection of revolutionary features that includes a two-way communication and feedback feature, a crane boosting feature, and an enhanced safety-monitoring feature.

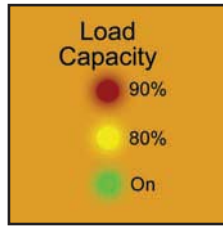

- The new Stellar® CDT™ equipped cranes are the first in the mechanics crane market to offer integral capacity alert into the handheld controller. This system alerts the operator of increasing loads before they reach maximum capacity.

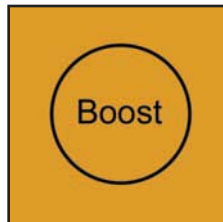

- Through the use of proprietary technology, the Stellar® CDT™ system can also allow operators who exceed standard capacity to productively operate through that situation by increasing crane capacity to 118% of its normal operating capacity for a short period of time.



- The new Stellar® CDT™ equipped cranes feature an enhanced safety system. If a device intended to monitor the capacity of the crane operates incorrectly, the crane will put itself into safe mode. Safe mode will allow the operator to work with the crane at a reduced speed until the safety device is in proper working order.



For questions or to place an order, please contact HAWKEYE TRUCK EQUIPMENT at 515-289-1755 or 1-800-622-8223.