

Heavy Duty Extendible Tail Hoist

NEX Series



- Heavier Duty 10" mainframe with no subframe making it capable of handling heavier loads
- Low loading angle without losing your 48 degree dump angle
- Great for scrap applications
- Inside controls standard reducing the chance of driver injury
- Durable rear hinge designed to withstand the stress of grueling day after day use



The Galfab Advantage



Outboard Supported Side Rollers

Greasable roller shaft is removable with two bolts.



Wear Strips

Strips on top and bottom of the mainframe help prevent wear and reduce friction.



Lowest Loading Angle

Low loading angle is great for areas with low overhead and loading containers with loose debris.



80" Extendible Tail

Extendible tail gives your container added support while not losing your 48 degree dump angle.

Standard Features

- 10 x 4" Tube Main Frame
- 2 1/2" Diameter Rear Hinge
- All Working Points Greasable
- 1" Spring Loaded Container Locks
- 2 1/2" Diameter Lift Cylinder Shafts
- 10" Diameter Vertical Front Sheave
- 10" Diameter Horizontal Sheaves
- 10" Diameter Sheave Blocks
- 52 Gallon Oil Reservoir
- Suction Screen and Return Filter
- Inside and Outside Controls
- Sealed Lighting System

Options

- Behind Cab and Oversize Oil Tanks
- Tool Boxes
- Auxiliary Stops
- Poly or Steel Fenders
- Tarping Systems
- Hooker Hold On Systems
- Ratchet Tie Down Straps
- Pintle Hook
- Front Mount Pump
- PTO
- Drop Shaft

DISTRIBUTED BY:

HAWKEYE TRUCK EQUIPMENT

515-289-1755

(800) 622-8223

Heavy Duty Extendible Tail Hoist

NEX Series

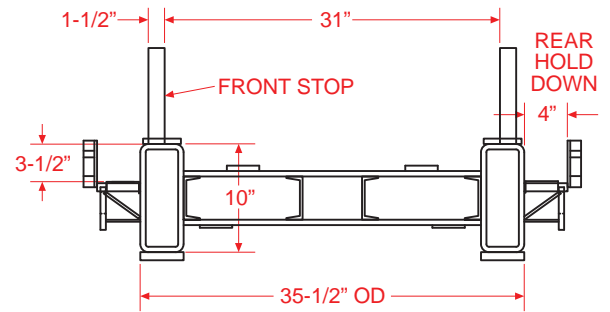
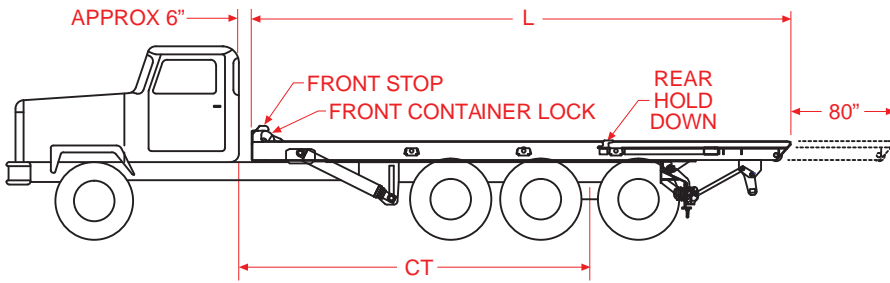

HOIST FRAME DETAILS

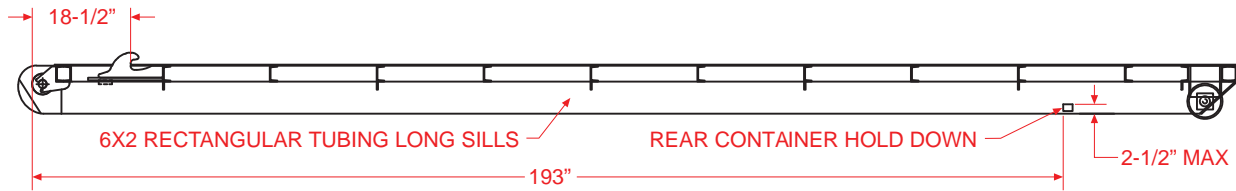

OUTSIDE RAIL CONTAINER REQUIREMENTS

Model	Rated Cap.	CT	L	Dump Angle	Up (Sec.)*	Down (Sec.)*	On (Sec.)*	Off (Sec.)*	Lift Cylinder	Winch Cylinder	Container Length	Appx. Wgt.
NEX 60174 T121	60,000#	174"	19' 10"	48 deg.	43	20	46	37	6" - 5" - 4" x 121" DAT	7" x 3" x 81 1/2" DA	18' to 22'	
NEX 60194 T121	60,000#	194"	22' 4"	48 deg.	43	20	51	42	6" - 5" - 4" x 121" DAT	7" x 3" x 91 1/2" DA	20' to 24'	
NEX 60225 T152	60,000#	225"	28' 1"	46 deg.	60	24	72	59	6" - 5" - 4" x 152" DAT	7" x 3" x 91 1/2" DA	24' to 28'	

* Cycle Times are Factory developed and controlled by PTO output, oil viscosity, human and mechanical efficiency, and may vary accordingly.

All dimensions are subject to steel and manufacturing tolerances.

CAUTION: This Equipment Should be Operated by Properly Trained Personnel. Improper Use, Misuse or Lack of Maintenance Could Cause Injury to Persons or Property. Photos used in this brochure are illustrative only. We reserve the right to make changes at any time without notice. Information contained within this literature is believed to be the most accurate available at the time of printing.

Additional Features



Optional Back Up Camera



Optional Auxiliary Fold Down Stop



Optional Multi Bank Valve Systems