

Heavy Duty Outside Rail Hoist

NOR Series



- 10" mainframe and 75k capacity making it capable of handling heavy loads
- Great for scrap applications
- Inside controls standard reducing the chance of driver injury
- 48 degree dump angle on all models
- Durable rear hinge designed to withstand the stress of grueling day after day use
- 2 minute loading cycle time* keeping your drivers on the road



The Galfab Advantage



Outboard Supported Side Rollers

Greasable roller shaft is removable with two bolts.



Wear Strips

Strips on top and bottom of the mainframe help prevent wear and reduce friction.



Auto Fold Bumper

Bumper folds forward reducing the chance of bending and hang-ups in the landfill.



Container Support Rails

Rails aid in loading misaligned containers and give added support the long sills increasing the life of your container.

Standard Features

- 10 x 4" Tube Main Frame
- 2 1/2" diameter Rear Hinge
- All Working Points Greasable
- 1" Spring Loaded Container Stops
- 2 1/2" diameter Lift Shaft
- 12" diameter Vertical Front Sheave
- 10" diameter Horizontal Sheaves
- 12" diameter Sheave Blocks
- 52 gallon Oil Reservoir
- Suction Screen and Return Filter
- Inside and Outside Controls
- Sealed Lighting System

Options

- Behind Cab and Oversize Oil Tanks
- Tool Boxes
- Auxiliary Stops
- Poly or Steel Fenders
- Tarping Systems
- Hooker Hold On Systems
- Ratchet Tie Down Straps
- Pintle Hook
- Front Mount Pump
- PTO
- Drop Shaft

DISTRIBUTED BY:

HAWKEYE TRUCK EQUIPMENT

515-289-1755

(800) 622-8223

Heavy Duty Outside Rail Hoist

NOR Series

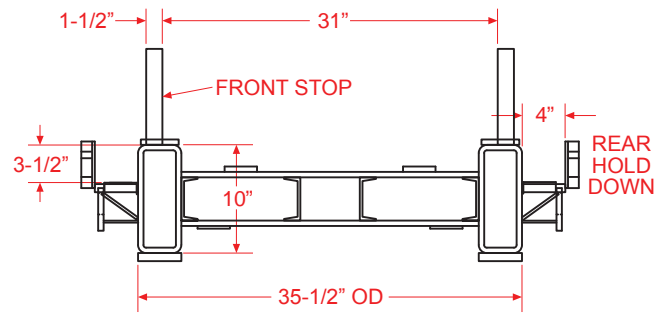
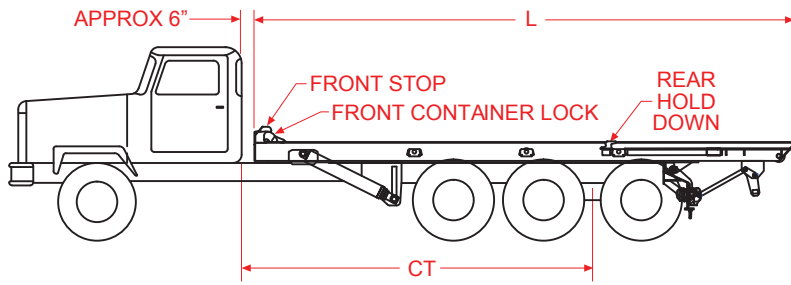

HOIST FRAME DETAILS

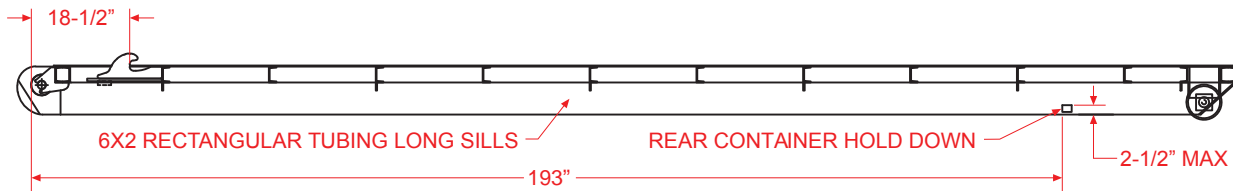

OUTSIDE RAIL CONTAINER REQUIREMENTS

Model	Rated Cap.	CT	L	Dump Angle	Up (Sec.)*	Down (Sec.)*	On (Sec.)*	Off (Sec.)*	Lift Cylinder	Winch Cylinder	Container Length	Appx. Wgt.
NOR 75174 T121	75,000#	174"	23' 2"	48 deg.	49	20	46	37	6" - 5" - 4" x 121" DAT	7" - 3" x 81 1/2" DA	18' to 22'	7931#
NOR 75182 T121	75,000#	182"	23' 10"	48 deg.	49	20	46	37	6" - 5" - 4" x 121" DAT	7" - 3" x 81 1/2" DA	18' to 22'	8215#
NOR 75194 T121	75,000#	194"	24' 11"	48 deg.	49	20	50	40	6" - 5" - 4" x 121" DAT	7" - 3" x 91 1/2" DA	20' to 24'	8781#

* Cycle Times are Factory developed and controlled by PTO output, oil viscosity, human and mechanical efficiency, and may vary accordingly.

All dimensions are subject to steel and manufacturing tolerances.

CAUTION: This Equipment Should be Operated by Properly Trained Personnel. Improper Use, Misuse or Lack of Maintenance Could Cause Injury to Persons or Property. Photos used in this brochure are illustrative only. We reserve the right to make changes at any time without notice. Information contained within this literature is believed to be the most accurate available at the time of printing.

Optional Features



Behind the Cab Oil Tank



Proximity Up Alarm Switch



Quad or Multiple Axle Packages