

EC2000

THE EC SERIES OF SERVICE CRANES BY



■ SPECIFICATION INFORMATION

Crane Rating: 6,500 ft-lbs (.99 ton-meters)
 Standard Boom Length: 4' (1.22 m) from CL of Crane

Boom Extension:
 • 1st stage: Manual 18" (45.72 cm)
 • 2nd stage: Manual 18" (45.72 cm)

Max. Horizontal Reach: 7' (2.13 m) from CL of Crane

Maximum Vertical Lift:
 (from crane base) 10' 9" (3.28 m)

Boom Elevation: 0° to +21° to +56°

Stowed Height:
 (crane only) 59.5" (151.13 cm)

Mounting Space Required: 12" x 12" (30.48 x 30.48 cm)

Shipping Weight: 275 lbs (124.74 kg)

Controls: Tethered remote

Winch

- Rope Length: 40' (12.19 m)
- Rope Diameter: 3/16" (.48 cm)

Rotation: 340 degree manual
 (Optional 314 degree power rotation is also available)

Lifting Capacities:
 2000 lbs @ 3' 7" (907 Kg @ 1.09 m)
 930 lbs @ 7' (422 Kg @ 2.13 m)

NOTE: All Stellar cranes meet ANSI B30.5 and OSHA 1910.180 specifications.
 Specifications subject to change without notification.

■ EC2000 CAPACITY CHART

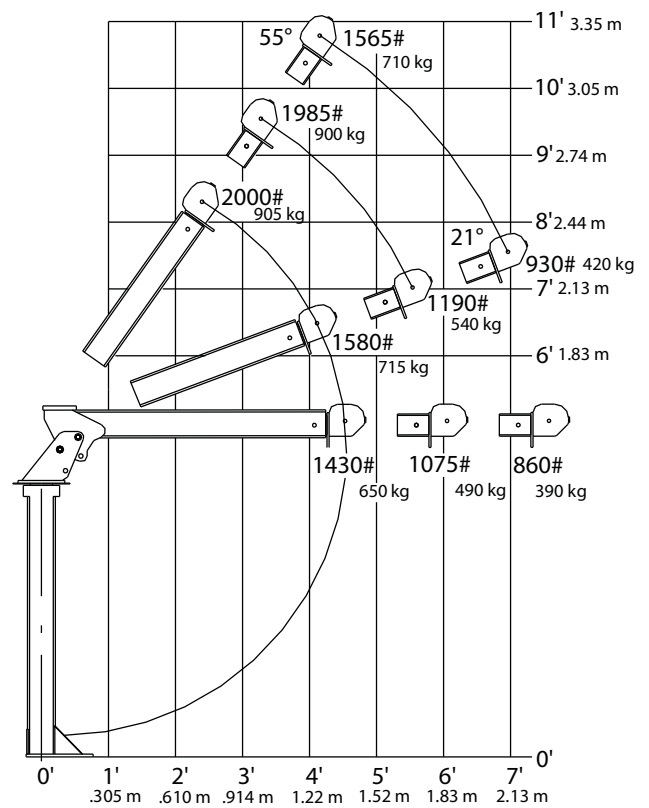

■ HOLE MOUNTING DETAIL

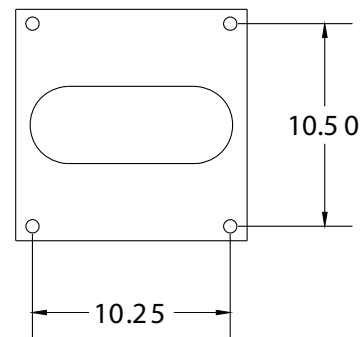

For questions or to place an order, please contact HAWKEYE TRUCK EQUIPMENT at 515-289-1755 or 1-800-622-8223.