

ILFP SLIDE LIFT

3000 and 4000 lbs. Capacity

HAWKEYE TRUCK EQUIPMENT

515-289-1755 or 1-800-622-8223

MBB PALFINGER



—OPTIMIZED—
FLEXIBILITY
DURABILITY
PROFITABILITY

The ILFP Slide Lift is designed for swing & roll up door equipped trucks & trailers and combines features like unobstructed dock loading access with a flat slimline column lift type platform.

The Heavy-duty and simple construction with feature such as slide in power pack and torsion assisted flip over section provides a user-friendly sliding lift with a large 58" or 77" x 84" platform at a low weight.



HEAVY DUTY CONSTRUCTION:

- Heat treated pins, bushings and zerks at all pivot points
- Laser cut parts for perfect alignment
- Thermo protected power pack inside mount frame
- Pre-installed power pack, wired, and filled with all weather multi-temp hydraulic fluid

BUILT IN STANDARD / SAFETY FEATURES:

- Large slimline steel - aluminum platforms with low incline ramps (58" x 84" & 77" x 84")
- Level ride platform with MBB PALFINGER smart touch technology for ease of loading on un-even grounds
- Torsion spring assisted aluminum tip section
- Reliable MBB PALFINGER cylinders equipped with hydraulic lock valves directly at cylinder ports

The ILFP series combines the simplicity of a two cylinder folding lift and incorporates the pre-mounted, protected power pack and heavy duty mount frame that is the backbone of our versatile program.

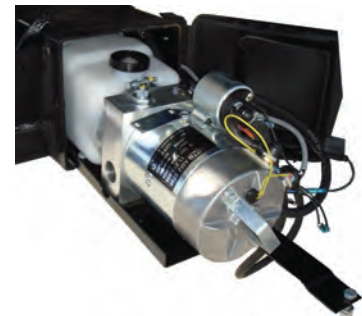
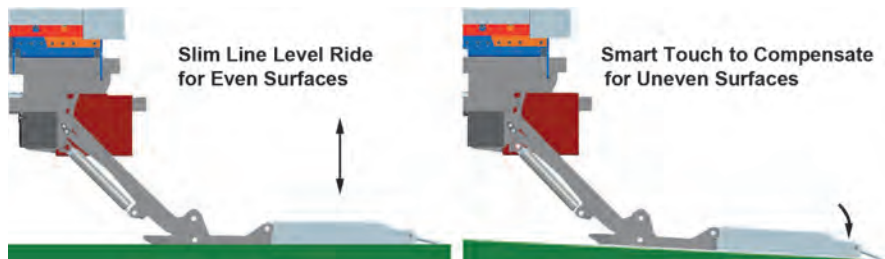

The MBB PALFINGER smart touch flat platform is able to compensate for different loads and terrain while maintaining level during the travel.

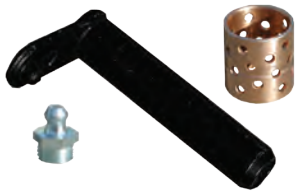

MBB PALFINGER liftgates are built with over-sized components for great reliability. The standard hydraulic cylinder locks provide added stability, better user control, and improve operator safety.

The thermo-protected power pack is fully enclosed in the mount tube for protection and slides out for fast inspection. By using oversized and thermo-protected quality components MBB PALFINGER minimizes maintenance and down time for customers.

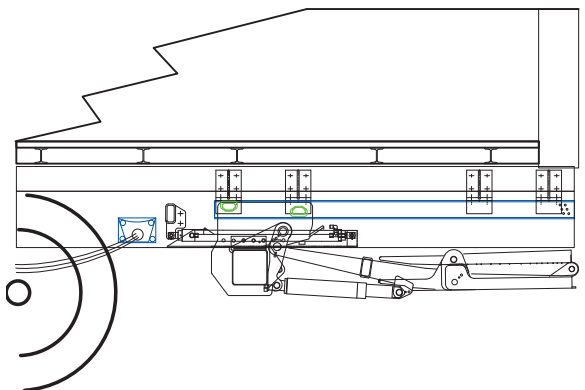

STANDARD FEATURES:

- ❑ Level ride
- ❑ 150 AMP circuit breaker
- ❑ On-off switch
- ❑ Torsion assisted aluminum tip section
- ❑ Bushings at all pivot points
- ❑ Hydraulic cylinder locks
- ❑ Pre-mounted, enclosed power pack inside mount frame

LIFTGATE OPTIONS:

- ❑ Hand held remote
- ❑ Auxiliary truck and trailer kits
- ❑ Carts stops
- ❑ Extra heavy duty trailer dock bumpers
- ❑ "DOT" rear impact guard
- ❑ Platform mounted foot controls
- ❑ Folding retention ramps

Model	Lifting Capacity (lbs)	Platform Length (inches)	Platform Width (inches)	Bed Height (inches)	Approx.Weight (lbs)	Mount Clearance (inches)
ILFP 30	3000	58 - 77	84	35 - 53	1350 - 1450	64 - 76
ILFP 40	4000	58 - 77	84	35 - 53	1390 - 1490	64 - 76