

ILSL SIDE LOADER LIFT

3300 | 4400 lbs. Capacity

PALFINGER

LIFETIME EXCELLENCE

For questions or to place an order, contact
HAWKEYE TRUCK EQUIPMENT
515-289-1755 or 1-800-622-8223

A LARGE PLATFORM LIFT FOR
TRAILER SIDE LOADING



OPTIMIZED CONSTRUCTION

- » Heat treated pins, bushings and zerks at all pivot points
- » Laser cut parts for perfect alignment
- » Thermo protected power pack inside mount frame
- » Pre-installed power pack, wired, and filled with all weather multi-temp hydraulic fluid

STANDARD | SAFETY FEATURES

- » Large slimline steel - aluminum platforms with low incline ramps (36"+5" or 72"+8" ARR x 72" wide)
- » Level ride platform with PALFINGER smart touch technology for ease of loading on uneven ground
- » Single or dual piece platform depending on platform depth
- » Reliable PALFINGER cylinders equipped with hydraulic lock valves directly at cylinder ports
- » Level ride
- » 150 AMP circuit breaker
- » Lockable control box & on-off switch
- » Torsion assisted aluminum tip section
- » Bushings at all pivot points
- » Hydraulic cylinder locks

LIFTGATE OPTIONS

- » Hand held remote
- » Trailer kits
- » Dual foot operated cart stops
- » Platform mounted foot controls
- » Folding retention ramps
- » Dual pump and motor
- » 84" wide platform
- » Trail charger kits
- » Solar panel charge kits
- » Warning lights

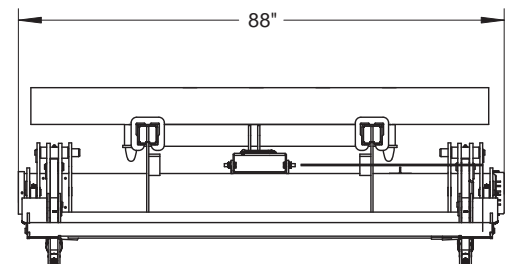
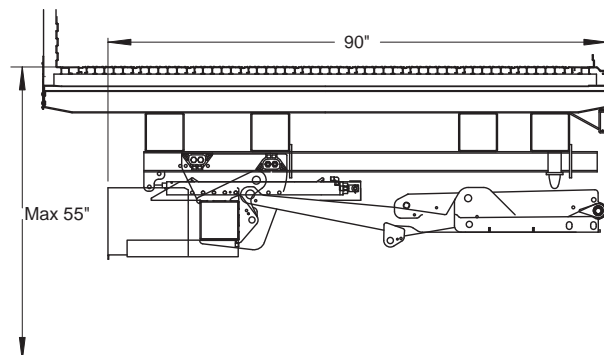

HIGHLIGHTS

The ILSL series combines the simplicity of a two cylinder lift and incorporates the pre-mounted, protected power pack and heavy duty mount frame that is the backbone of our versatile program.

The heavy duty and simple construction features a slide-in power pack and torsion assisted, flip-over section providing a user-friendly sliding lift with a large 36"+5" or 72"+8" ARR x 72" wide platform at a low weight.

SMART TOUCH TECHNOLOGY

The PALFINGER smart touch flat platform is able to compensate for different loads and terrain while maintaining level during the travel.

HYDRAULIC CYLINDER LOCKS

PALFINGER liftgates are built with oversized components for great reliability. The standard hydraulic cylinder locks provide added stability, better user control, and improve operator safety.



POWERPACK

Single pump units are enclosed in the mount tube for protection and slides out for fast inspection. Dual pump units are placed in a pre-mounted box attached to the frame

By Using thermo-protected quality components we minimize maintenance and down time.



Model	Lifting Capacity (lbs.)	Platform Length (Inches)	Platform Width (Inches)	Bed Height (Inches)	Approx. Weight (lbs.)	Mount Clearance (Inches)
ILSL 33	3300	36+5 fixed & 72+8 ARR	72	40 - 55	1250 - 1450	84 - 88
ILSL 44	4400	36+5 fixed & 72+8 ARR	72	40 - 55	1280-1480	84 - 88