

The Best Choice

Choice #1 Single Cable System

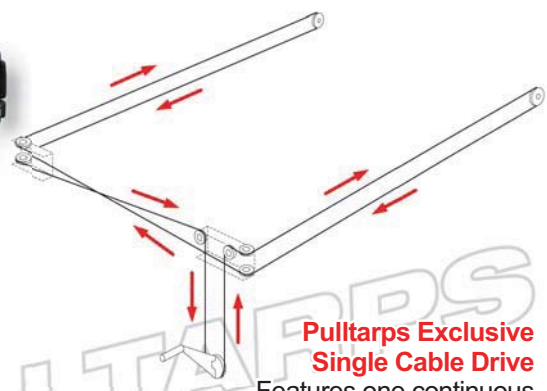

Pulltarps Exclusive Single Cable Drive
Features one continuous cable that crosses in front of the trailer. Because the rear drive bow is attached to the same cable, it is impossible for the bows to jam or get out of time.

Choice #2 Twin Cable System

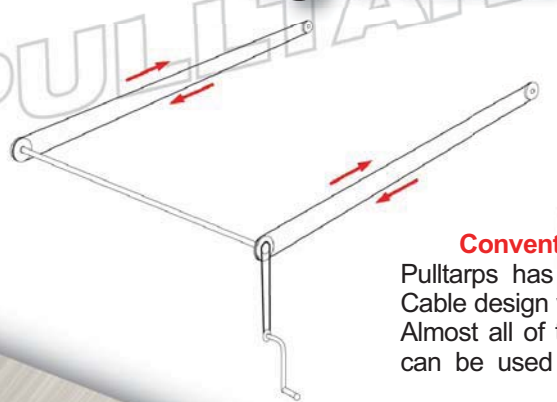

Conventional Twin Cable Drive
Pulltarps has improved on the Twin Cable design with higher quality parts. Almost all of the parts in our System can be used to repair and upgrade other brands.



Simply the Best!

Cable Systems



Pulltarps' Cable System designs have been the biggest improvement in front to back cable systems since their beginning over 20 years ago. All systems are rugged and reliable featuring zinc plated or aluminum parts for rust protection and better appearance. The bows are 1 1/8" galvanized steel and can be replaced without removing the cable. The UHMW Sliders are guaranteed* to never wear out and are not harmed by asphalt, UV rays, ice or hot weather. They also provide smooth operation with less friction and wipe the top rail clean of dirt and debris.

Single Cable Super Slider

The Super Slider Cable System uses the Single Cable drive design for a smooth and jam free operation. The bows are all attached to the same cable making it impossible for the bows to become misaligned. The Super Slider features a unique tarp design that brings 5" of fabric down over the top rail for better coverage.

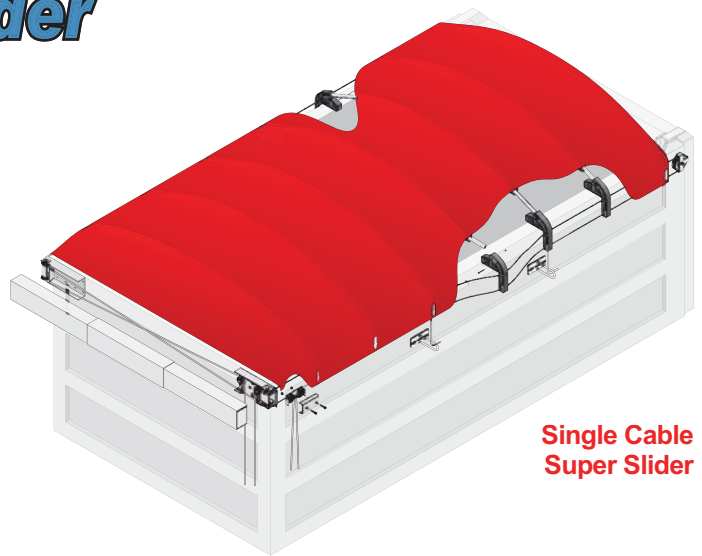

Single Cable Super Slider



The Closer complements the Super Slider Cable System by closing off the rear of the tarp at the tailgate automatically. There is no rear flap to tie off and no more climbing up on the back of the trailer. This design forms a taper at the rear of the tarp when closed for better aerodynamics and fuel economy. The spring loaded Closer rear bow also holds the tarp up above the load as the tarp is extended. The Closer can be retrofitted to existing Super Slider Tarp Systems.



THE CLOSER

Single Cable Drive Options:



1. Hand Crank
(Part # 502-0501)
2. Hand Crank with Idler Pulley
(Part # 502-0502)

Hand Cranks

The rotating handle folds out of the way. The special locking mechanism secures the tarp when it is extended or retracted.

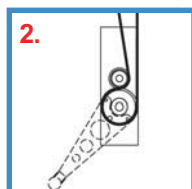
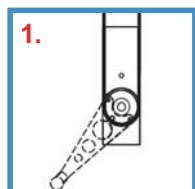

1. Motor Drive
(Part # 502-0601)
2. Motor with Gear Drive
(Part # 502-0602)

Electric Motor Drive

The 1.1hp Superwinch® motor is backed by a 3 year prorated manufacturer's warranty. 1.3hp motor also available.

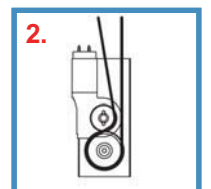
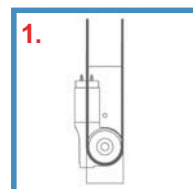

••All Electric Drive Options Come

Tarps

Paving the way in innovation, Pulltarps builds the best cable system tarps in the industry. Our tarps feature 2" wide heavy duty webbing sewn the full length down each side. The tarp lasts longer because they do not rub on the rails. The tarps include bow pockets sewn onto the tarp for added strength and longer wear. All cable tarps are tapered down in the front for better aerodynamics and fuel efficiency. Our cable system tarps make great replacement tarps for any brand of tarp system. A 14" straight rear flap is standard unless ordering a rear closer.

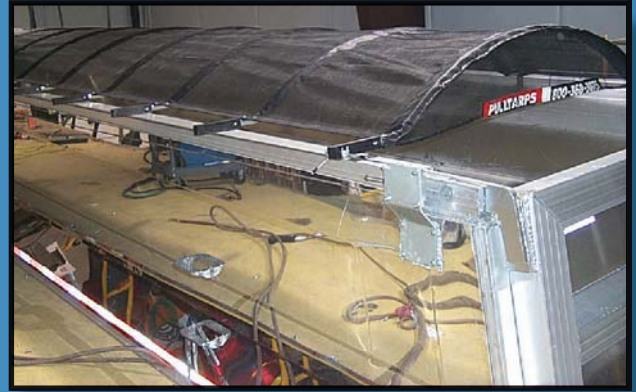

Single Cable Top Slider

The Top Slider Cable System uses the jam free single cable drive design with a tarp that covers the top of the opening. The UHMW sliders and single cable design make this the most dependable Top Slider Cable System available. You can tension the entire system with the turn of just one bolt at ground level. At the rear is a welded double drive bow to provide double the strength and a more stable base to prevent rocking.

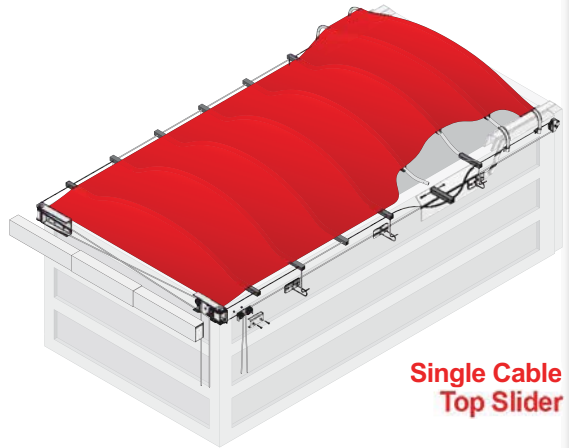

Single Cable Top Slider



Single Cable Top Slider

Twin Cable Top Slider

Twin Cable systems have been built by many manufacturers for over 20 years. The Twin Cable System uses a conventional tarp design that covers the top of the opening and the typical twin cable drive system. Pulltarps has improved the design with higher quality parts, UHMW sliders, and easily removable tarps. Rear Pulleys have a forward facing, easy tensioning adjustment. Almost all of the parts in our Twin Cable system are interchangeable with other brands.

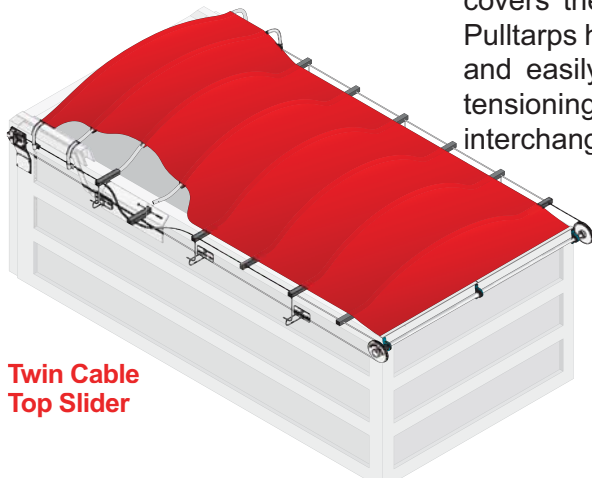

Twin Cable Top Slider



Twin Cable Top Slider

Twin Cable Drive Options:

1. **Direct Drive Hand Crank Assembly** (Part # 502-0503)
The direct drive long handle is great for shorter applications. (Included in System Price)
2. **Upper Gear Reduction Hand Crank** (Part # 502-0504)
Gear reduction makes longer or heavier tarps easier to crank.

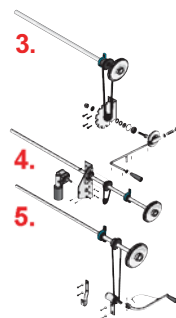

3. **Basic Hand Crank** (Part # 502-0591)
Interchangeable with other brands.

4. **Electric Motor Drive** (Part # 502-0610)
Powerful 1.1hp Superwinch® motor drive can be operated by wireless remote control, in-cab switch or external switch.

5. **Standard Chain Drive** (Part # 502-0505)
Easy to crank at ground level. The handle folds out of the way for easy storage.

Accessories



Air Gate Bows

Optional high lift Air Gate bows can be added to any top slider system. Air Gate Bows allow the tarp to be extended all of the way providing better coverage. For Top Sliders Only.

Part # 502-0403

Part # 502-0404



Smart Switch With Wireless Remote

Easy to install because there is no switch to wire. Unique transmitter codes do not interfere with other remote devices. Can be operated from 150 feet away.

12V Part # 501-9958



Heavy Duty Trailer Connector

For heavy duty and severe service applications. Great for longer wire runs. Large contacts resist corrosion. Highest amperage rating available.

Steel Mount Part # 514-0501

Aluminum Mount Part # 514-0502



1.3hp Motor Option

Systems can be ordered with an extra heavy duty 1.3hp Superwinch® electric motor. Great for longer applications.

Part # 517-0909

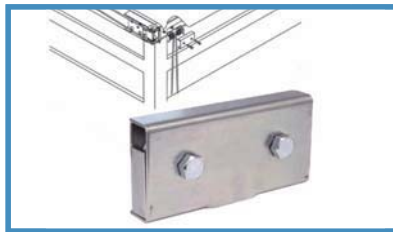

Side Pulley Box

Allows you to mount your electric drive or hand crank to the side of the body rather than the front. For Single Cable System

Part # 502-0108

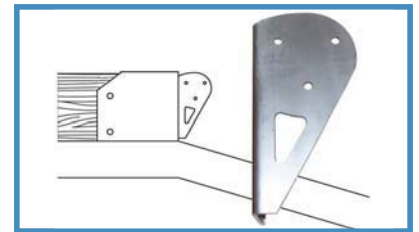

Belly Dump Rear Pulley Brackets

Used for mounting the rear pulleys to the back of a belly dump. Mounted flush against the rear board pocket so the tarp can cover the hopper completely.

Part # 502-0197 left

Part # 502-1101 right



Electric Motor Drive

The electric drive is the easiest way to cover long or short applications. Choose one of our Smart Switches for either in-cab, remote control, or external operation. For Twin Cable System.

Part # 502-0610

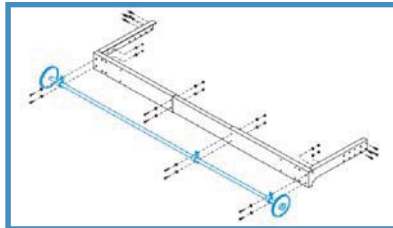

Front Frame Bracket

The Front Frame Bracket Kit allows you to mount your Twin Cable System out in front. The length is adjustable and works great for faster installations.

Part # 502-0103



Interchangeable Parts

Pulltarps® Twin Cable parts are interchangeable with other brands of tarp systems. Our higher quality parts are great for upgrading or repairing existing systems.

Simply the Best!

For questions or to place an order, contact HAWKEYE TRUCK EQUIPMENT at 515-289-1755 or 1-800-622-8223.

