

Stellar® Service Cranes and TMAX™ Service Bodies

4421



For questions or to
place an order, contact
HAWKEYE TRUCK EQUIPMENT
at 515-289-1755 or 1-800-622-8223

TECHNICAL SPECIFICATION GUIDE



Our People. Our Products.

STELLAR® 4421 TECHNICAL SPECIFICATION GUIDE

SPECIFICATION INFORMATION

Crane Rating:	16,000 ft-lbs (2.23 ton-meters)
Standard Boom Length:	11' (3.35 m) from CL of Crane
Boom Extension:	
• 1st Stage:	Hydraulic 60" (152.4 cm)
• 2nd Stage:	Manual 60" (152.4 cm)
Max. Horizontal Reach:	21' 0" (6.40 m) from CL of Crane
Max. Vertical Lift: (from crane base)	22' 7" (6.89 m)
Boom Elevation:	-10° to +80°
Stowed Height: (crane only)	31.2" (79.2 cm)
Mounting Space Req:	18" x 15" (45.7 x 38.1 cm)
Approximate Crane Weight:	4421 (electric) 2H: 1,155 lbs (524 kg) 1H1M: 1,120 lbs (507 kg)
	4421 (hydraulic) 2H: 1,065 lbs (482 kg) 1H1M: 1,025 lbs (465 kg)
Controls:	Radio control standard for all functions (Stellar® CDT™ control system optional)
Winch	
• Rope Diameter:	5/16" (0.79 cm) 6X19 IWRC-DGXIP X 90' (27.73 m)
• Line Pull Speed:	25 ft/min (7.62 m)
• Max. Single Part Line:	2,000 lbs (905 kg)
• Max. Double Part Line:	4,000 lbs (1815 kg)
Rotation:	370° power (worm gear)
Lifting Capacities:	4,000 lbs @ 4' (1810 kg @ 1.22 m) 760 lbs @ 21' (345 kg @ 6.40 m)
Power Supply Required:	12-volt power unit 2.0 gpm @ 2600 psi (7.57 lpm @ 179 bars)
Min. Rec. Chassis (GVRW)	14,500

NOTE: All Stellar cranes meet ANSI B30.5 and OSHA 1910.180 specifications. Specifications subject to change without notification.

DEFINING CHARACTERISTICS

Radio Control System

Every electric, on/off, or proportional 4421 comes standard with a radio remote control. Stellar is the market leader with standard radio remote controls.

Stellar® CDT™ (Crane Dynamics Technology™)

Standard on 4421 proportional hydraulic crane, the Stellar CDT control system is revolutionary to the telescopic service crane market and EXCLUSIVE TO STELLAR. This system features capacity alert to the handheld crane remote and also features a Safe Mode to keep the crane and operator safe should a load indicating device fail to operate correctly.

Internal Extension Cylinder

New to the 4421 crane is our new internal cylinder extensions system. Designed to the same standards of our larger cranes, you will find the looks and performance of our extension booms second to none.

Full Hydraulic Extension

The 4421 crane offers an optional boom configuration of two hydraulic boom extensions. The 4421 crane come standard with a one hydraulic, one manual boom configuration.

Market Leading Boom Articulation

The Stellar 4421 crane offers -10 degrees to +80 degrees. This gives the operator both easy reach to snatch block stowing and the best ability to load items into the load bed.

Quick Release Snatch Block Stow

The Stellar quick release snatch block stow, is installed on the underside of the boom to easily stow your snatch block after use. Its unique design gently releases the snatch block for use when the boom is raised at close to 60 degrees to ensure a safe and orderly deployment.

Planetary Winch

The planetary winch on every crane manufactured by Stellar was designed to match the capacity and hydraulic control system. It lifts the maximum crane load and offers the smoothest and fastest speeds in the market today to help keep your productivity at max levels.

Strong Rotation System

Stellar uses a durable rotation system with a cast iron base and an internal mechanical stop to provide the most durable rotation system found in the industry.

Counterbalance Valves

Each cylinder on the Stellar 4421 crane feature counterbalance valves to prevent unintended cylinder movement should a hose break.

Greaseable Pivot Bushings

Each pivot pin location on the 4421 crane includes bushings and grease zerks to provide for years of use.

Hexagonal Booms

Stellar Industries made the hexagonal boom design famous in the telescopic service crane market. This design provides for a stronger and better aligning boom than competitive square boom design.

Bar Style Anti-Two Block

The 4421 crane is equipped with a low profile bar style anti-two block system that allows for easy access to the tightest lifting locations.

4421 CAPACITY CHART

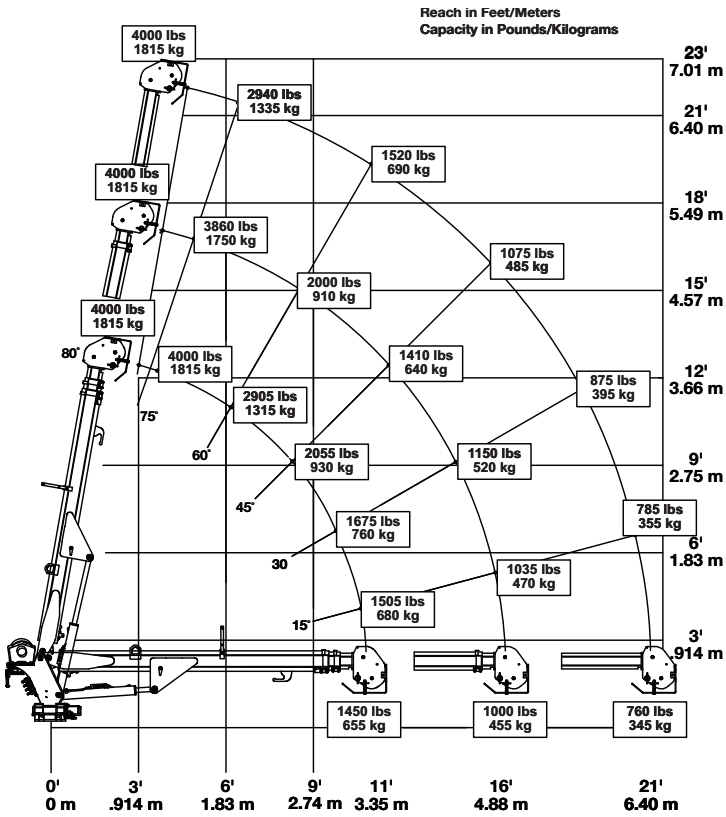

Weight of load handling devices are part of the load lifted and must be deducted from the capacity.

Maximum 1 part line capacity is 1600 lbs. (725 kg). For greater loads, use 2 part line.

GEOMETRIC DIMENSIONS

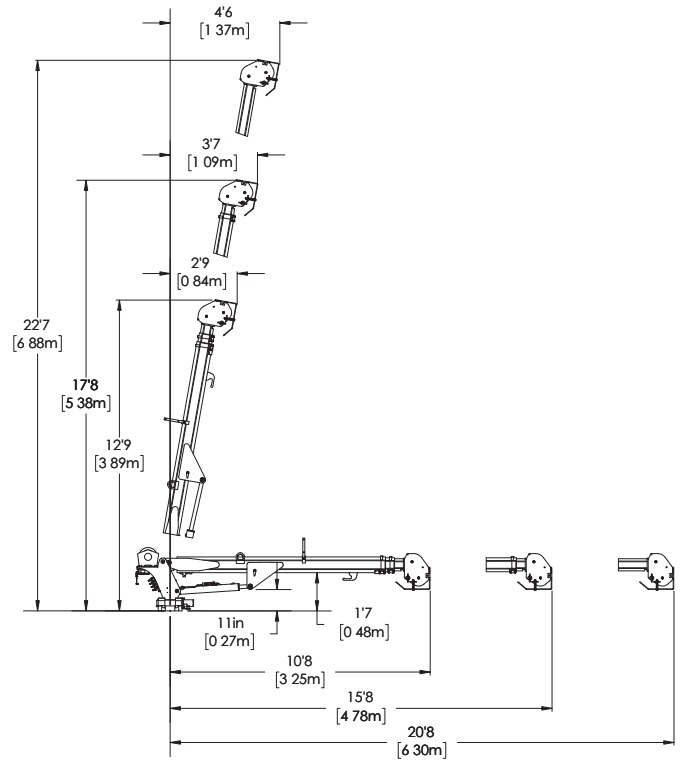

ROTATIONAL CLEARANCE

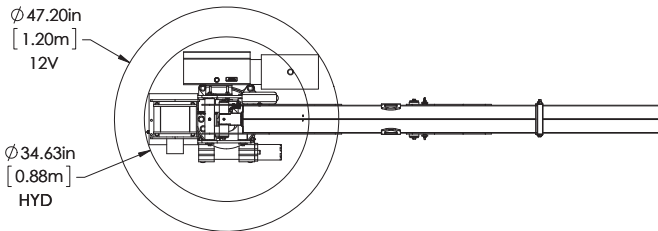

DIMENSIONS

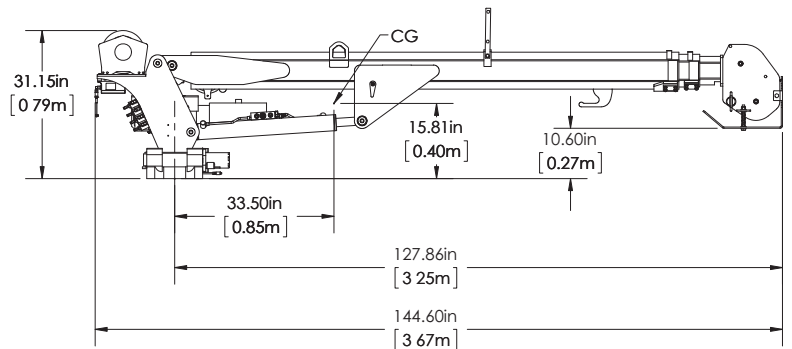

NEW TMAX™ Service Body

TMAX1™ Service Body

Applicable Chassis: 16000 GVWR to
19000 GVWR Chassis

Compatible Crane Models: 3315
4421
5521
7621
7630

Cab to Axle: 84" (213.36 cm)
Body Length Nominal: 133" (337.82 cm)
Body Height: 44" (111.76 cm)
Body Width: 94" (238.76 cm)
Compartment Depth: 22" (55.88 cm)
Floor Width: 50" (127 cm)
Net Weight: 3220 lbs (1460.37 kg)

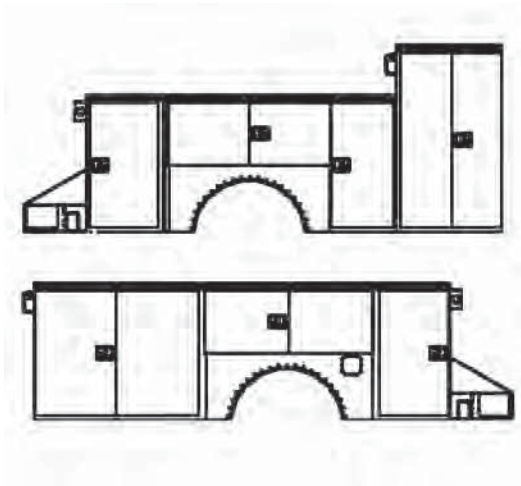

Your local distributor:



Our People. Our Products.

For questions or to place an order,
contact **HAWKEYE TRUCK EQUIPMENT**
at 515-289-1755 or 1-800-622-8223